

This Page Is Inserted by IFW Operations
and is not a part of the Official Record

BEST AVAILABLE IMAGES

Defective images within this document are accurate representations of the original documents submitted by the applicant.

Defects in the images may include (but are not limited to):

- BLACK BORDERS
- TEXT CUT OFF AT TOP, BOTTOM OR SIDES
- FADED TEXT
- ILLEGIBLE TEXT
- SKEWED/SLANTED IMAGES
- COLORED PHOTOS
- BLACK OR VERY BLACK AND WHITE DARK PHOTOS
- GRAY SCALE DOCUMENTS
- BLANK PAGES

IMAGES ARE BEST AVAILABLE COPY.

**As rescanning documents *will not* correct images,
please do not report the images to the
Image Problem Mailbox.**

(12) **UK Patent Application** (19) **GB** (11) **2 347 950** (13) **A**

(43) Date of A Publication 20.09.2000

(21) Application No 0003251.6
(22) Date of Filing 11.02.2000
(30) Priority Data
(31) 60119611 (32) 11.02.1999 (33) US

(71) Applicant(s)
Shell Internationale Research Maatschappij B.V.
(Incorporated in the Netherlands)
Department IP/43 Carel Van Bylandtlaan 30,
2596 HR The Hague, Netherlands

(72) Inventor(s)
Robert Lance Cook
David Paul Brisco
R Bruce Stewart
Lev Ring
Richard Carl Haut
Robert D Mack

(51) INT CL⁷
E21B 33/047 // E21B 43/10

(52) UK CL (Edition R)
E1F FJR FLA

(56) Documents Cited
None

(58) Field of Search
UK CL (Edition R) E1F FJR FLA
INT CL⁷ E21B
Online: JAPIO, EPODOC, WPI

(74) Agent and/or Address for Service
Hasettine Lake & Co
Imperial House, 15-19 Kingsway, LONDON,
WC2B 6UD, United Kingdom

(54) Abstract Title
Method of forming a wellhead

(57) A wellhead is formed by extruding a plurality of tubular liners 1520, 1530, 1535 off of a mandrel into contact with an outer casing 1510. The first tubular liner 1520 and mandrel are positioned within the wellbore with the tubular liner in an overlapping relationship with the outer casing 1510. At least a portion of the tubular liner is extruded off of the mandrel into contact with the interior surface of the outer casing 1510. The first tubular liner is extruded off of the mandrel by pressurizing an interior portion of the first tubular liner. Subsequent tubular liners 1530, 1535 are positioned in concentric overlapping relation and similarly extruded off of a mandrel into at least partial contact with the interior surface of the outer casing 1510.

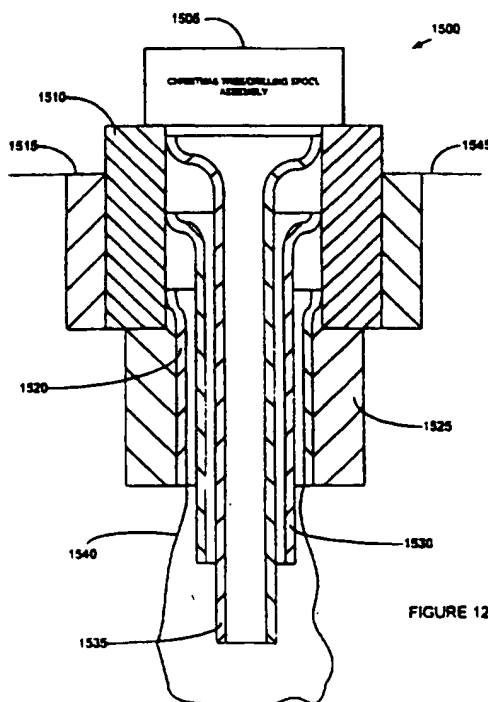

FIGURE 12

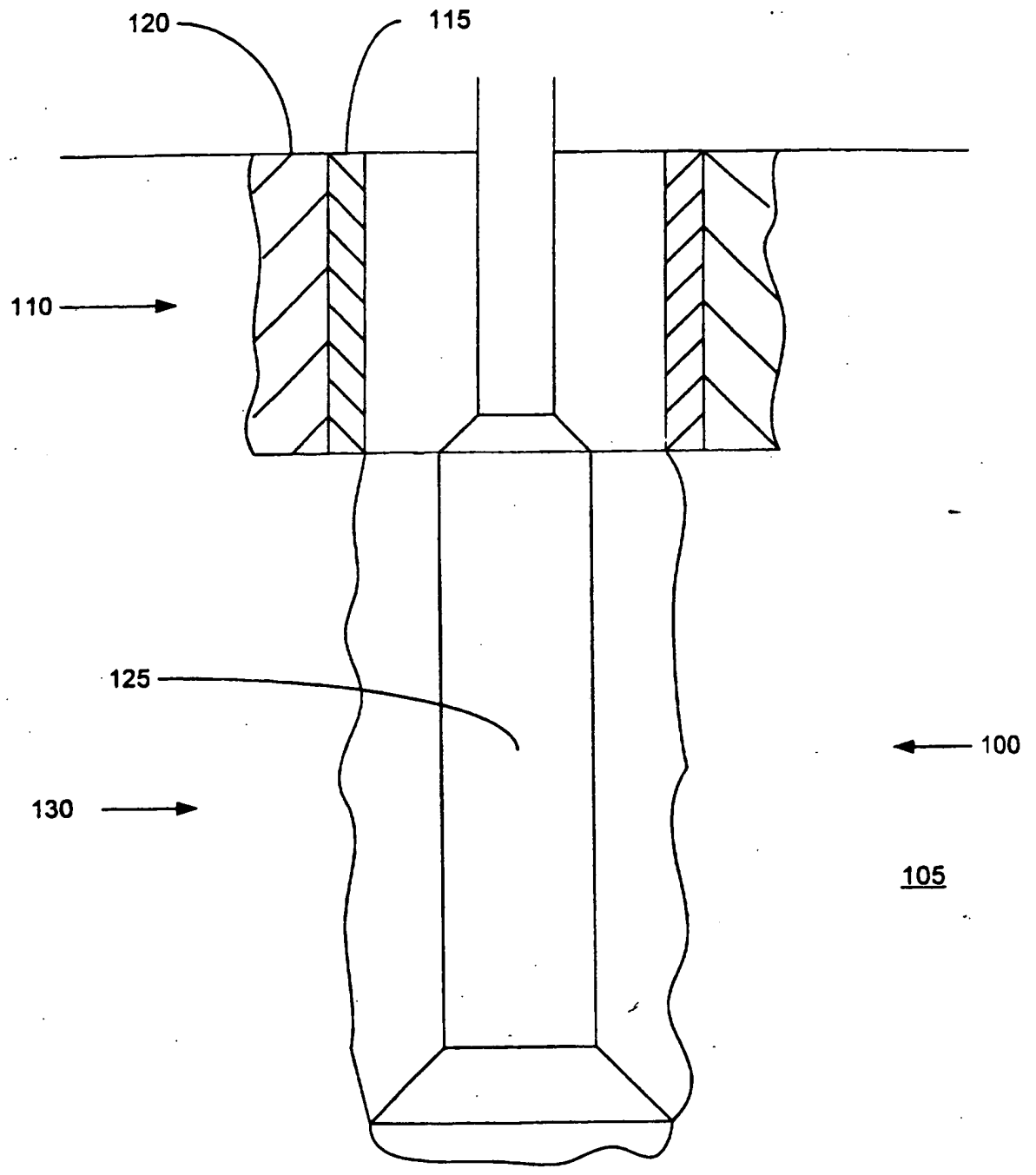

FIGURE 1

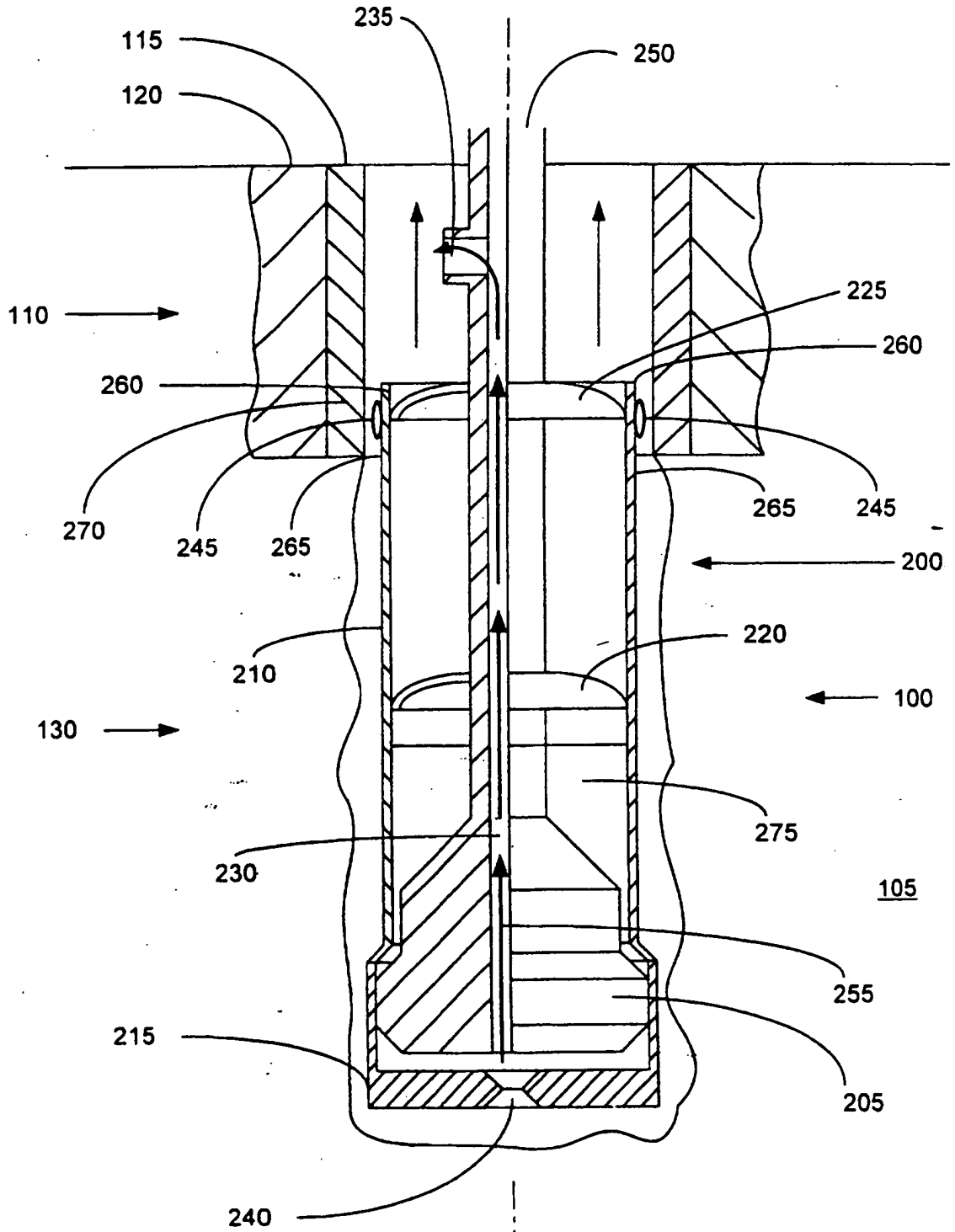

FIGURE 2

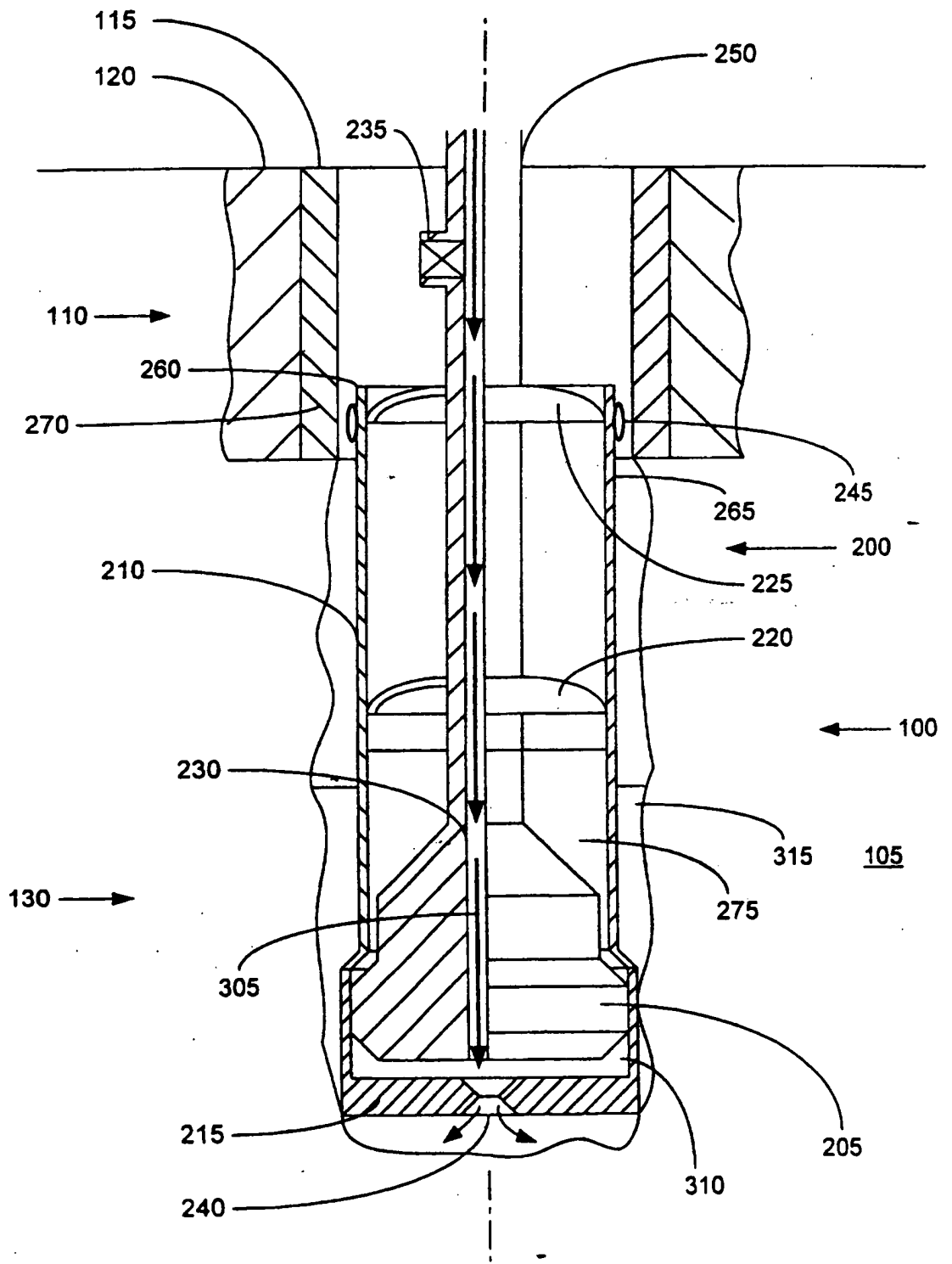

FIGURE 3

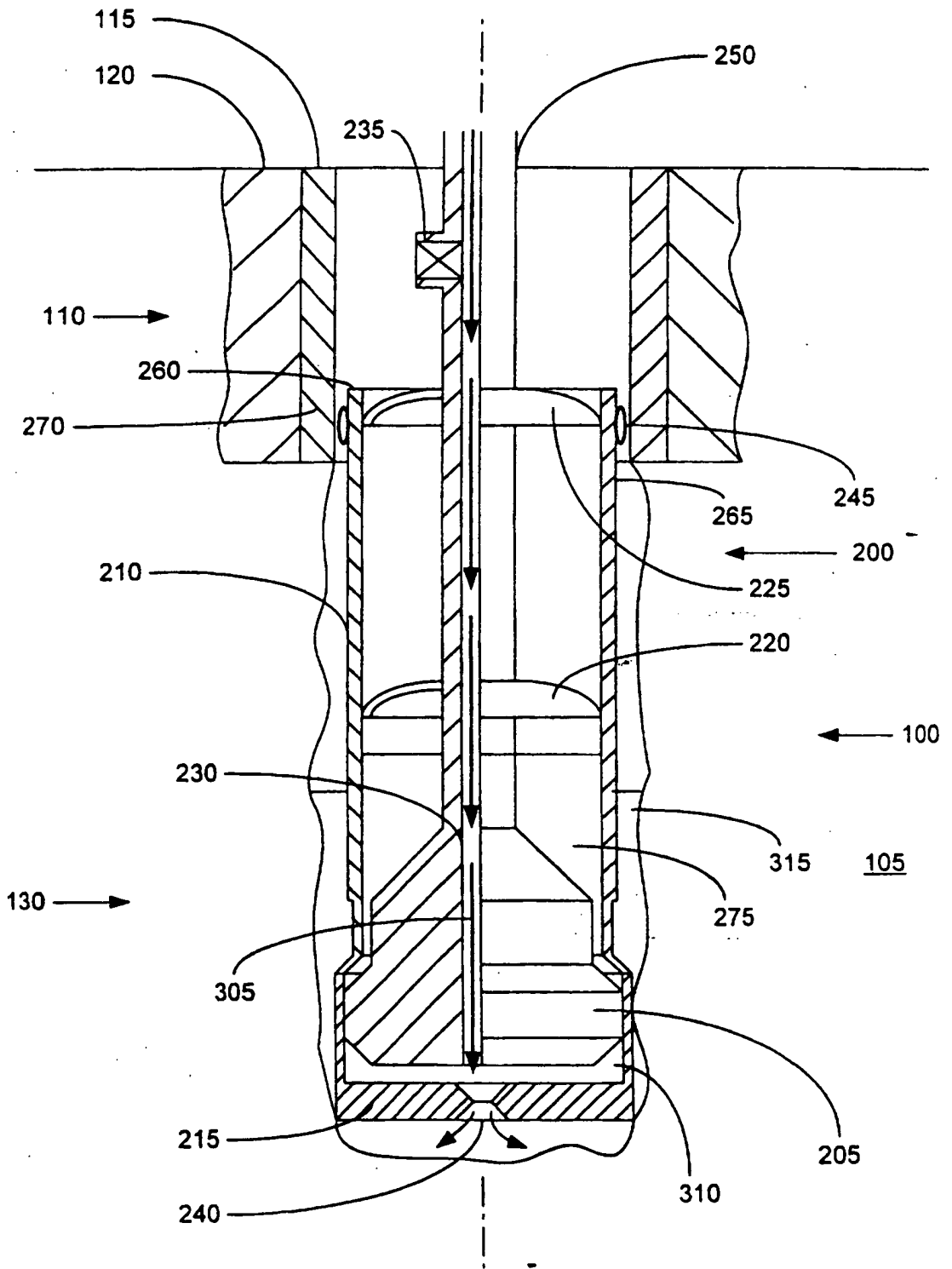

FIGURE 3a

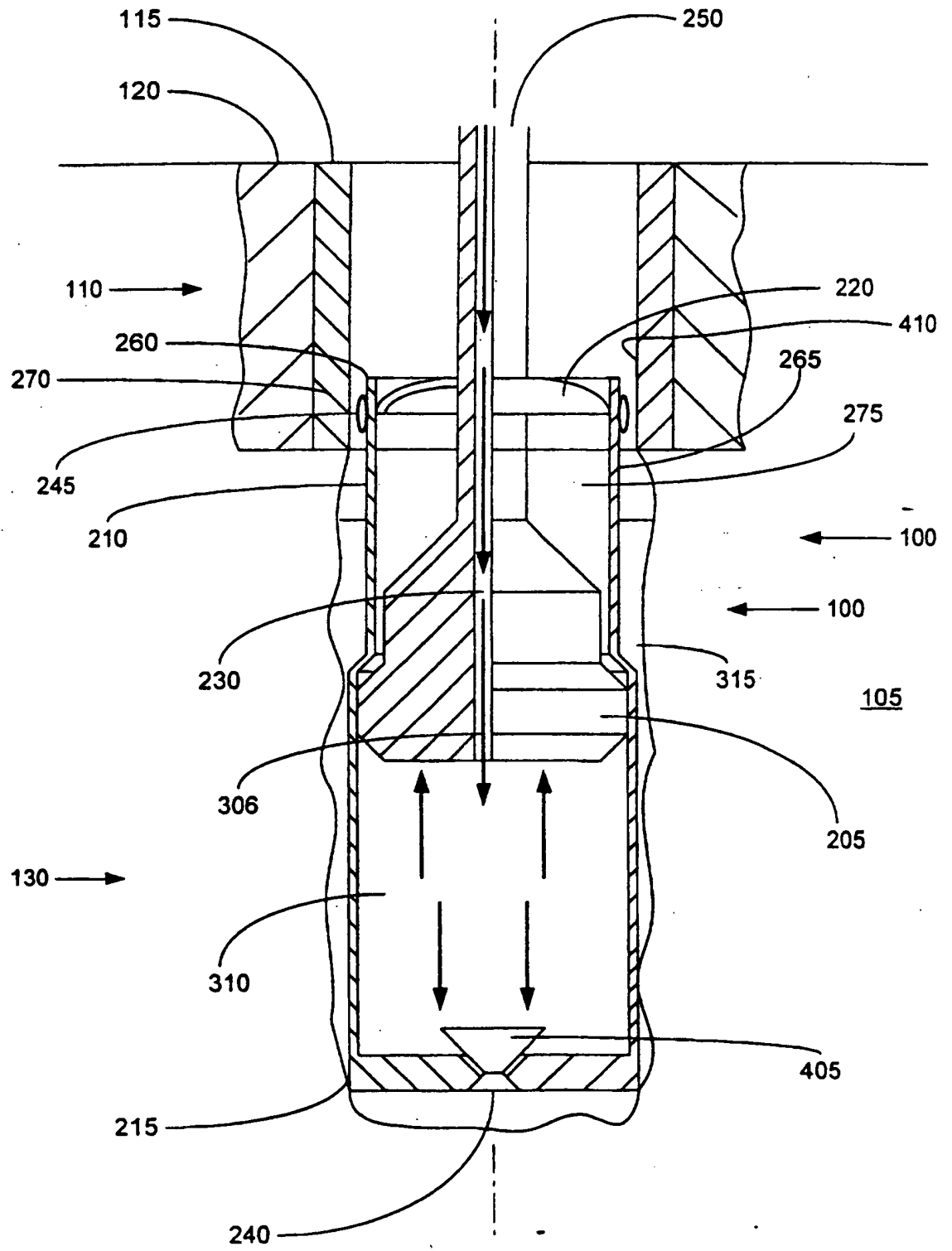

FIGURE 4

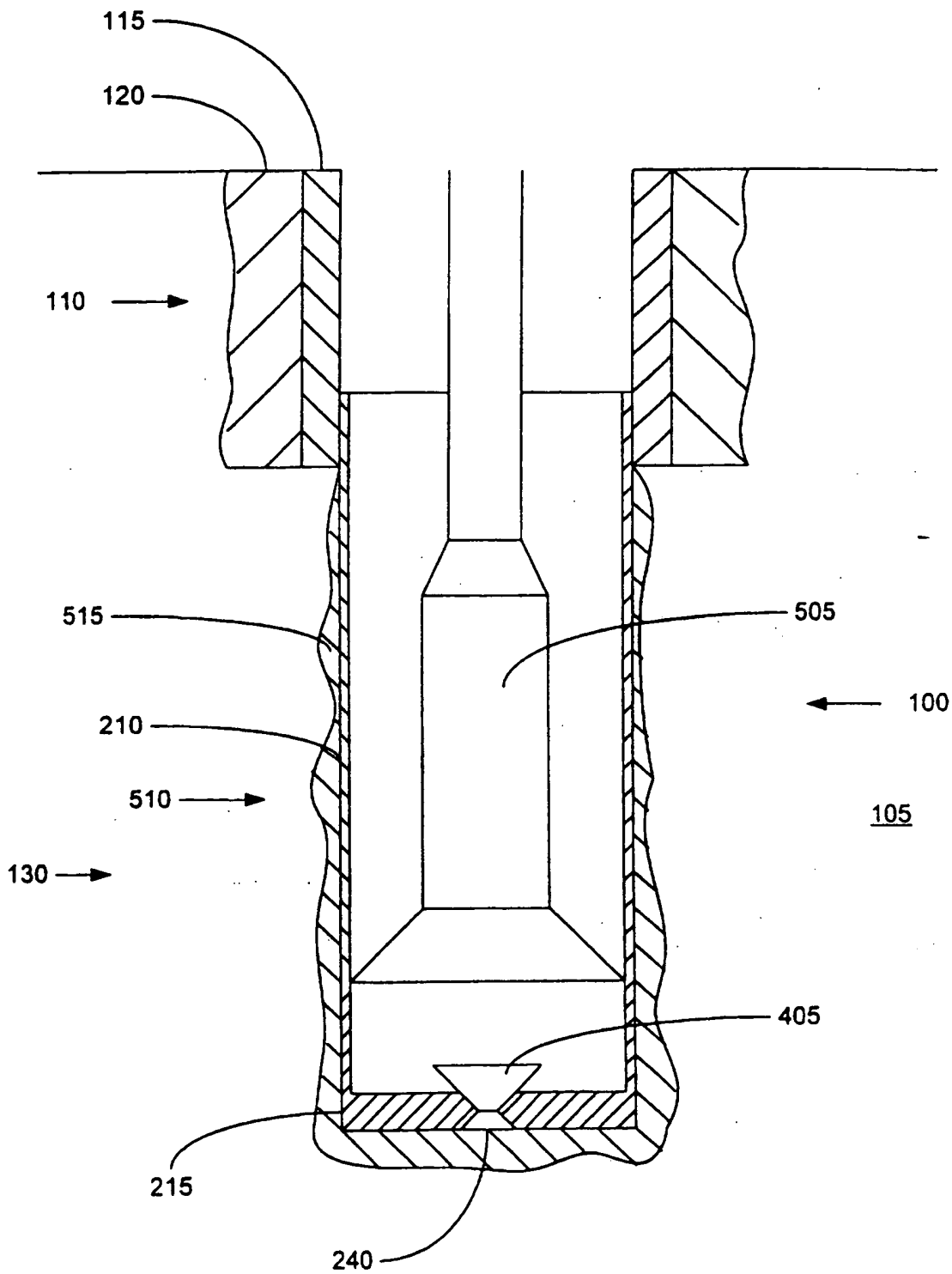

FIGURE 5

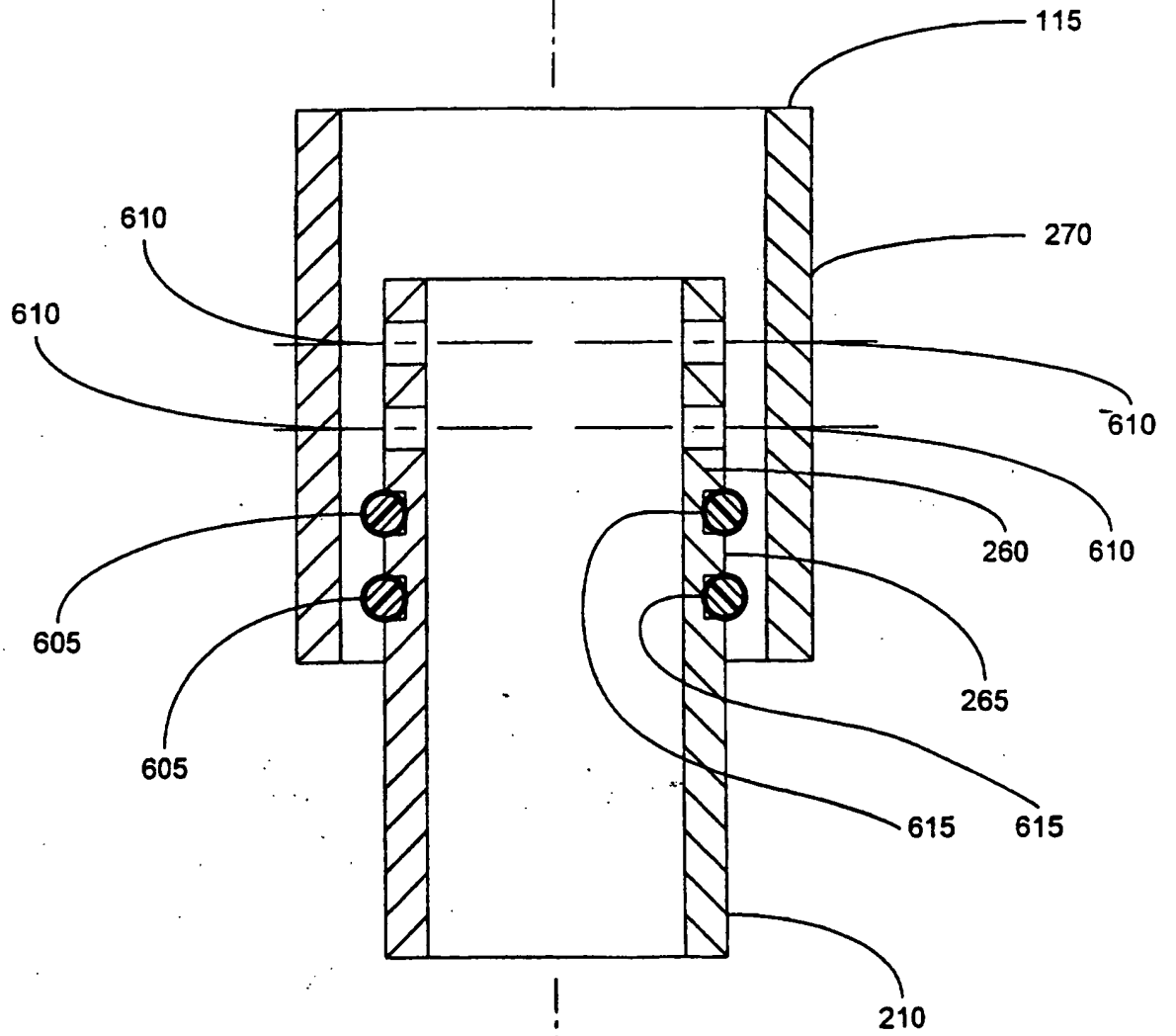

FIGURE 6-

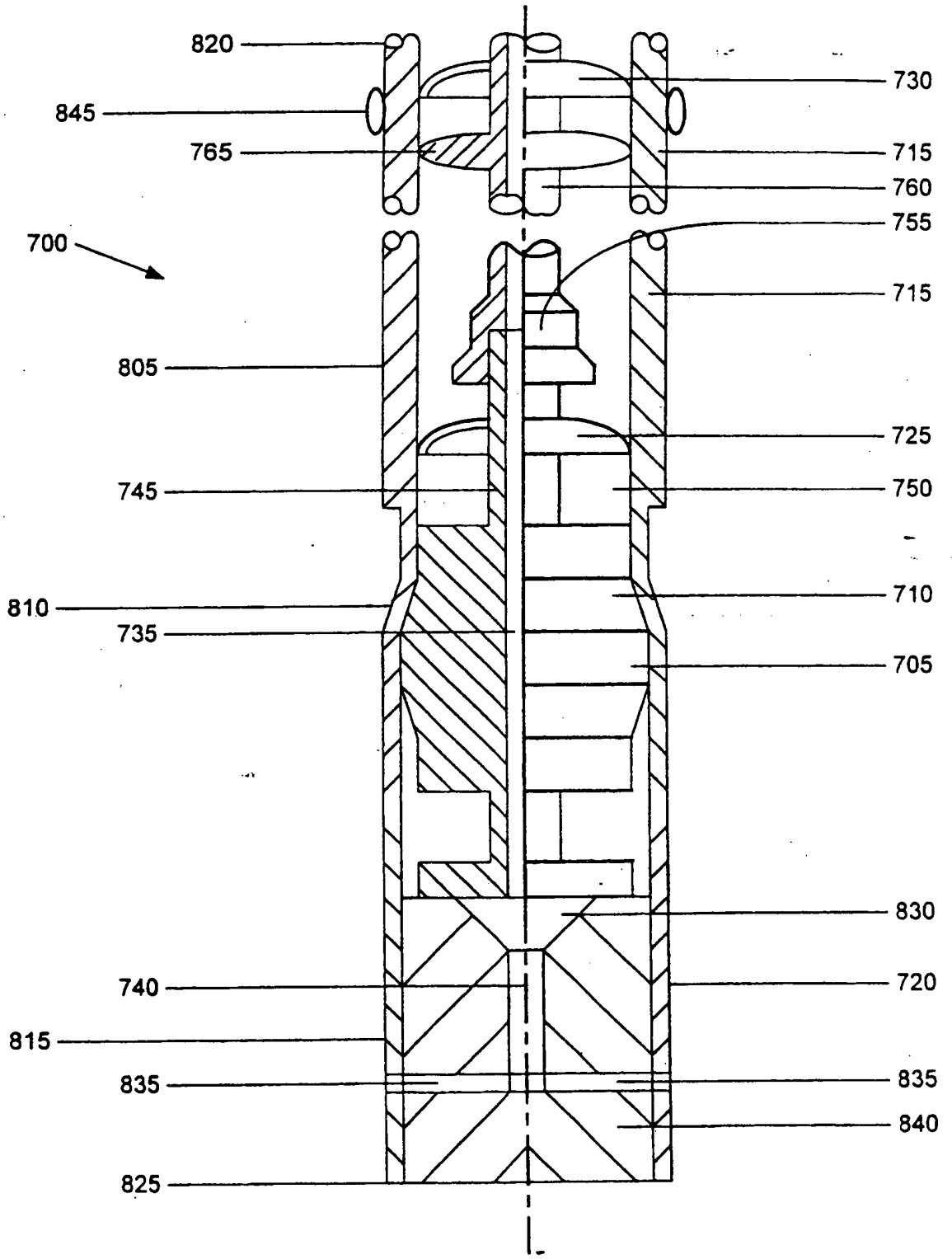

FIGURE 7

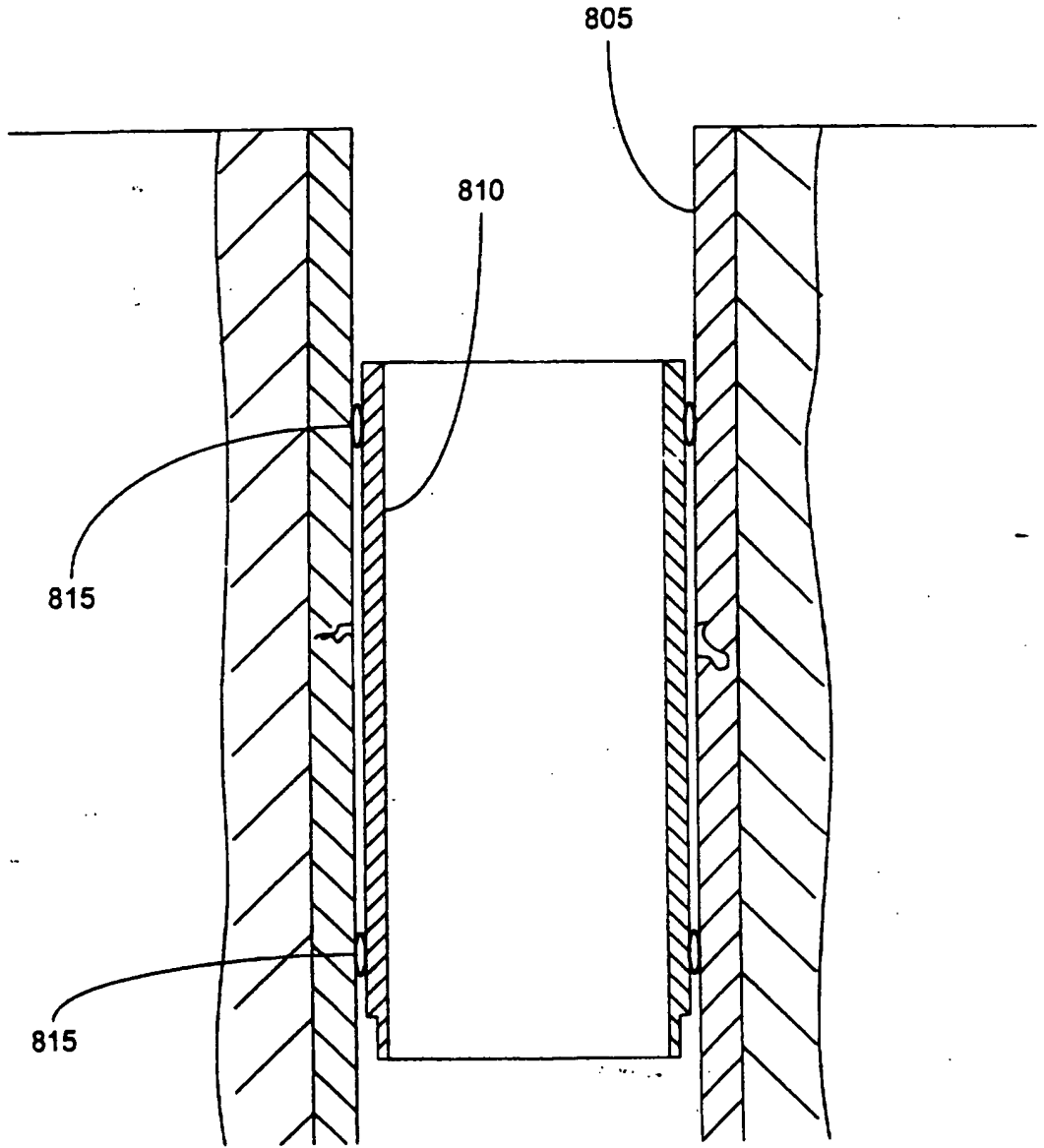

FIGURE 8

10/28

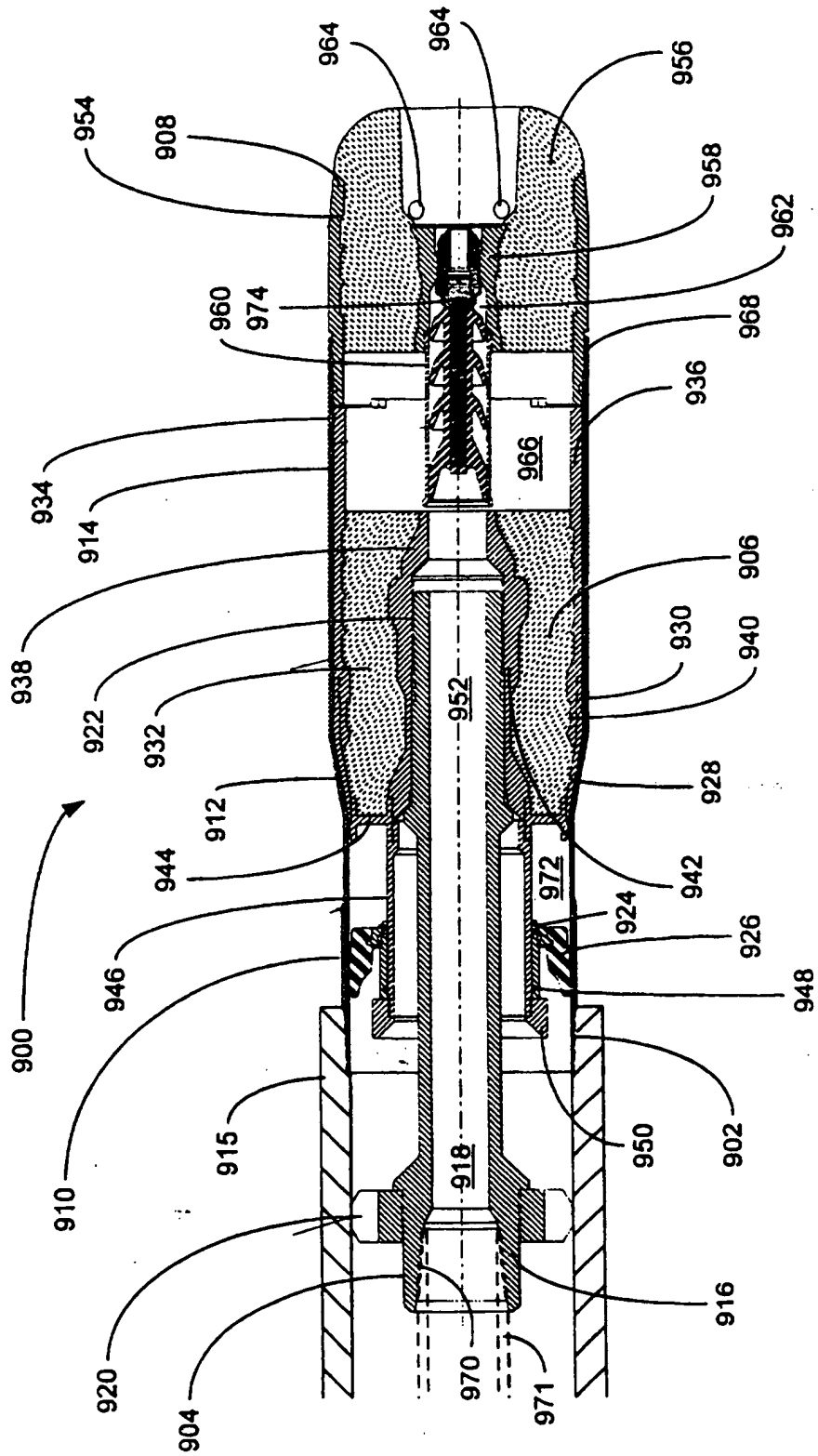

FIGURE 9

12/28

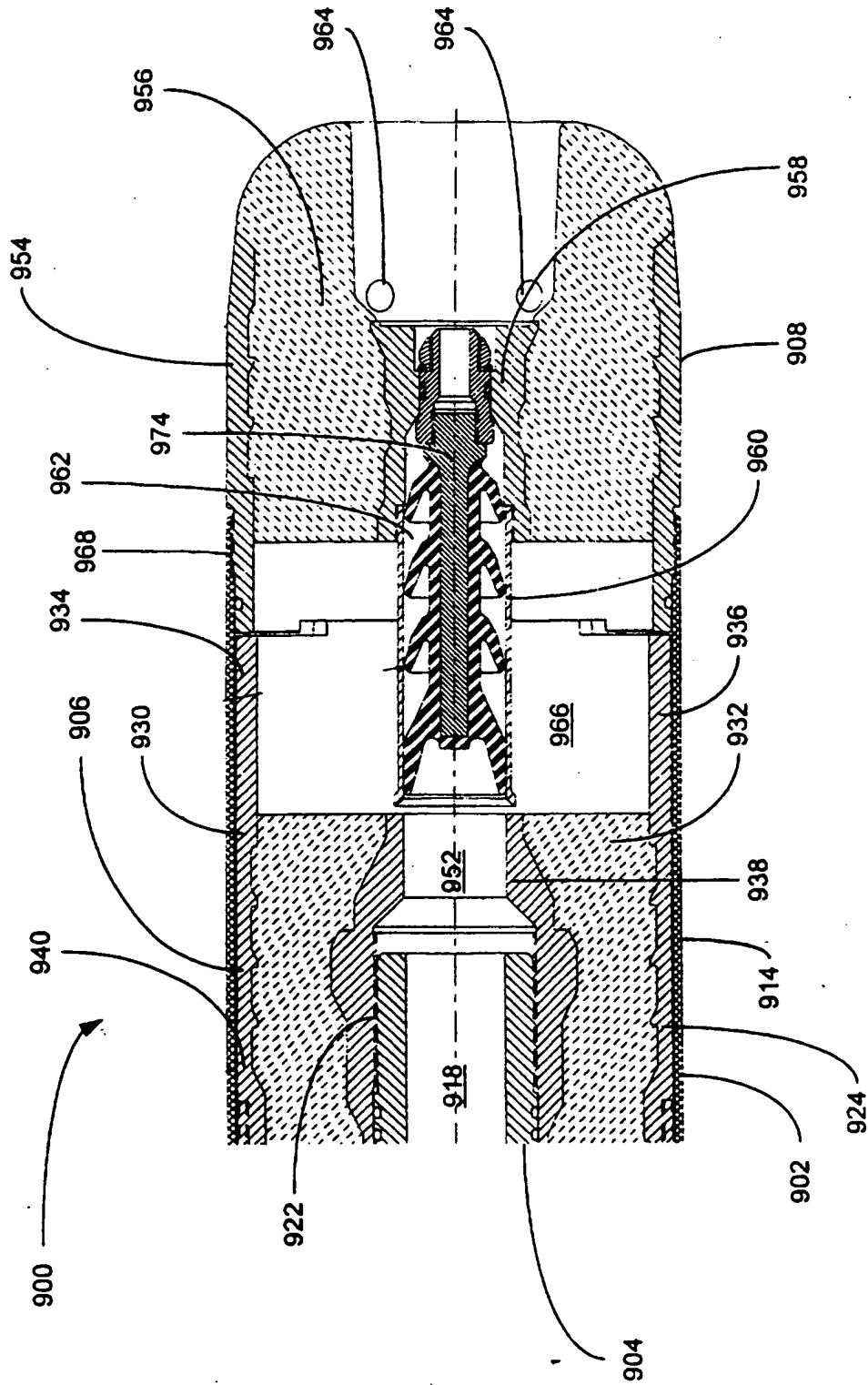

FIGURE 9b

13/28

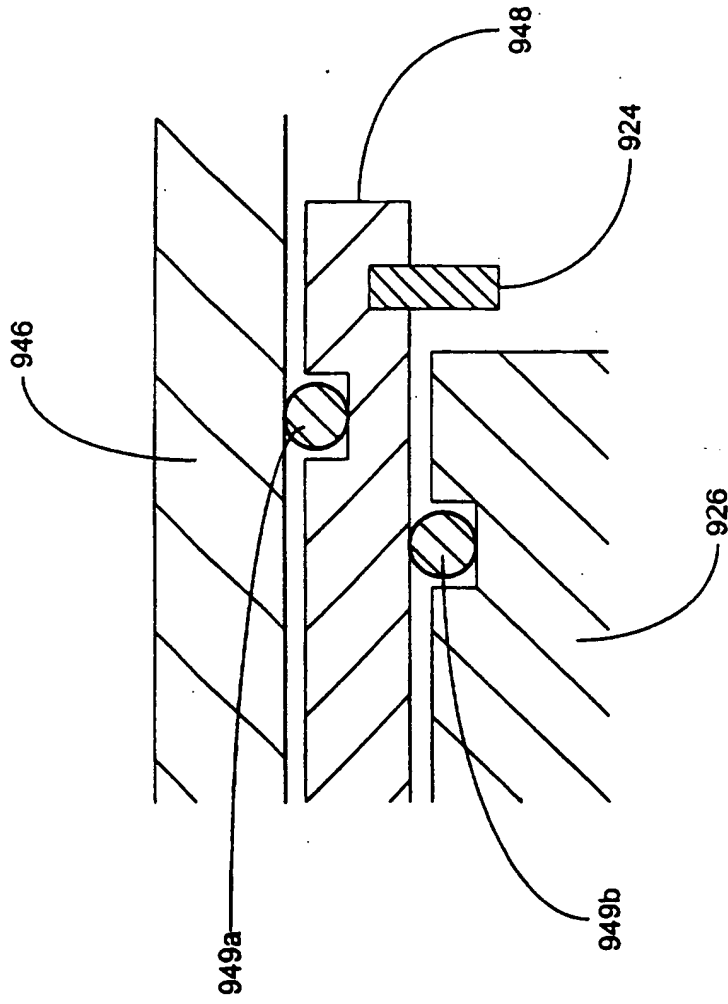

FIGURE 9C

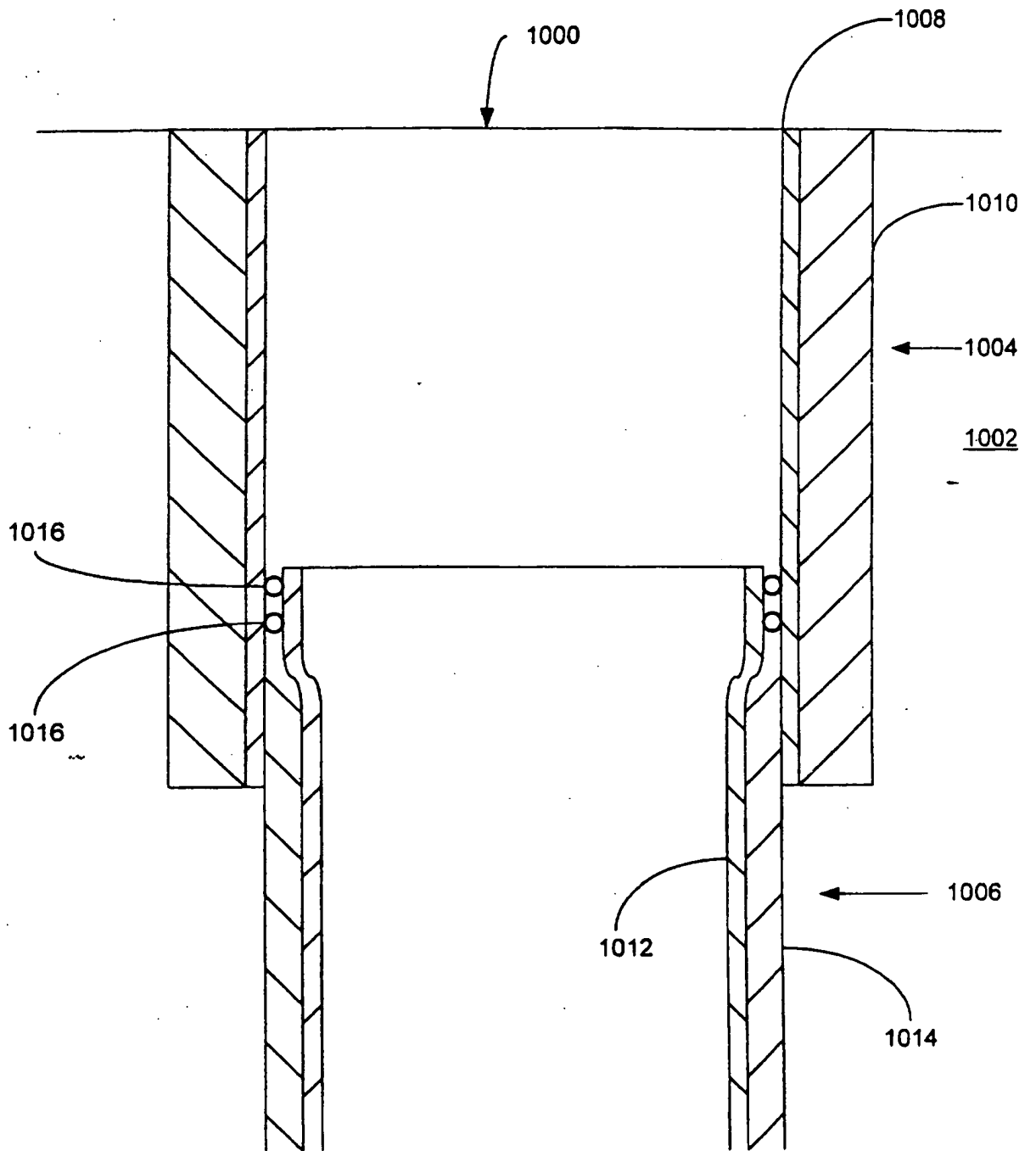

FIGURE 10a

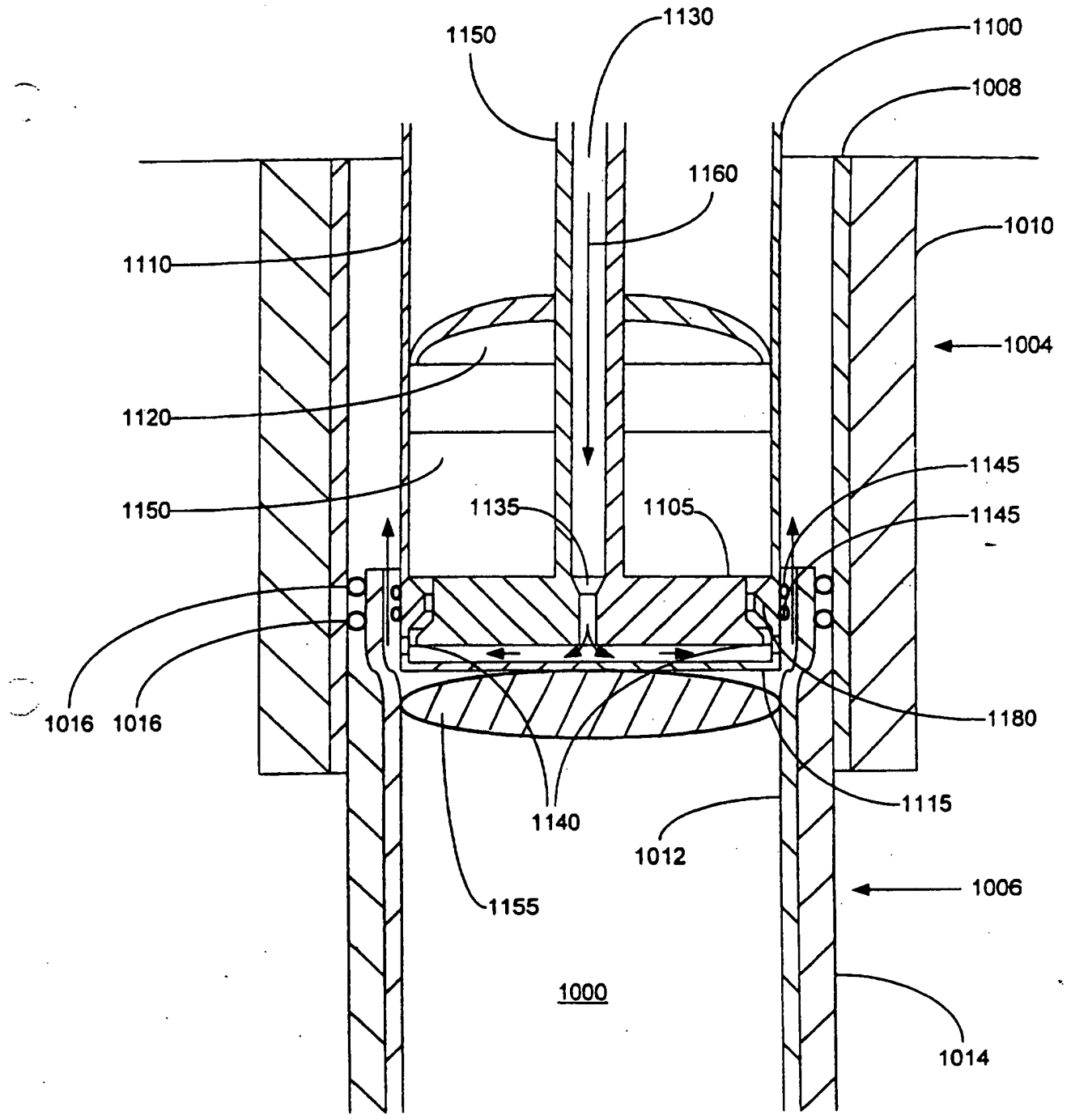

FIGURE 10c

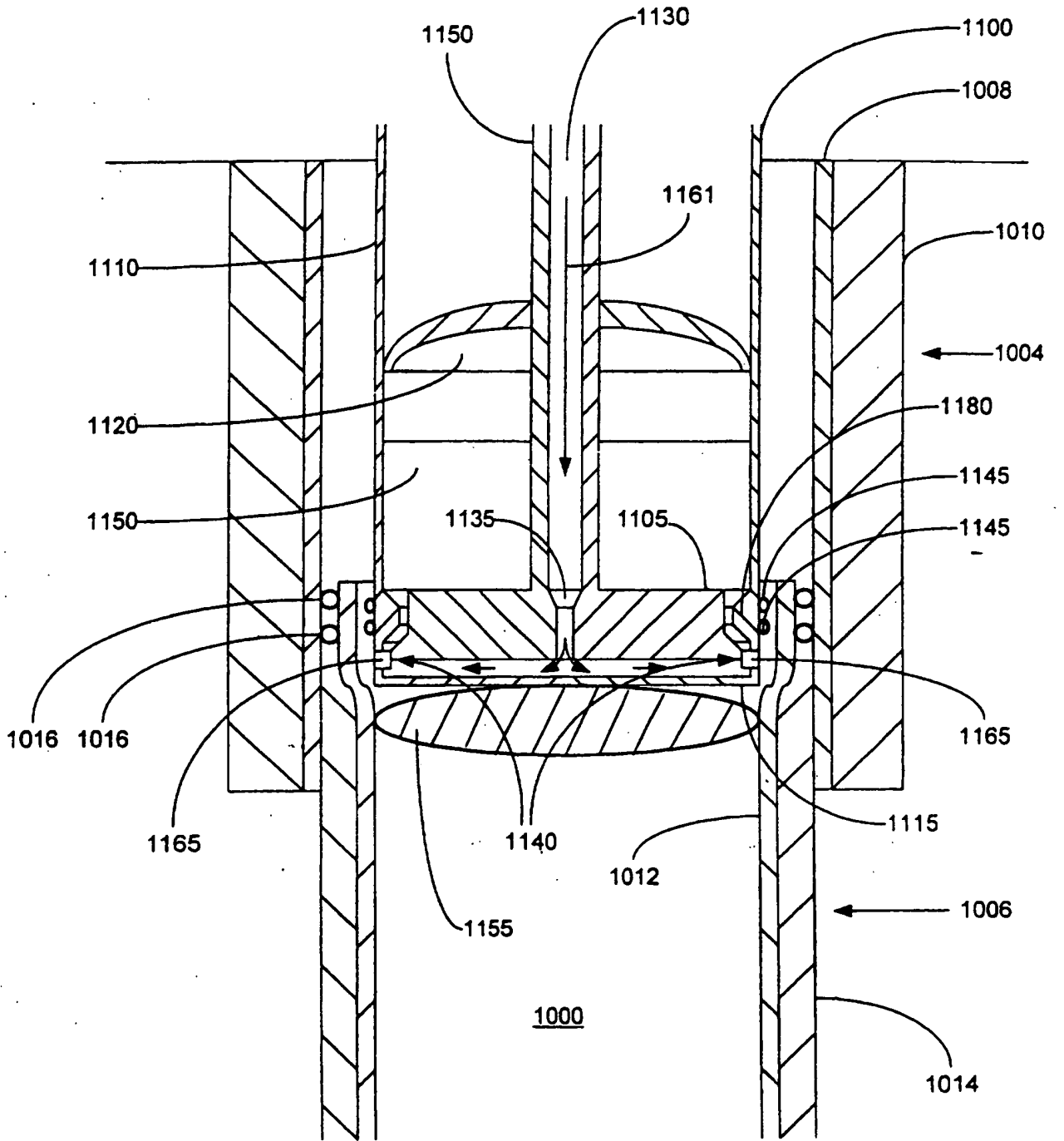

FIGURE 10d

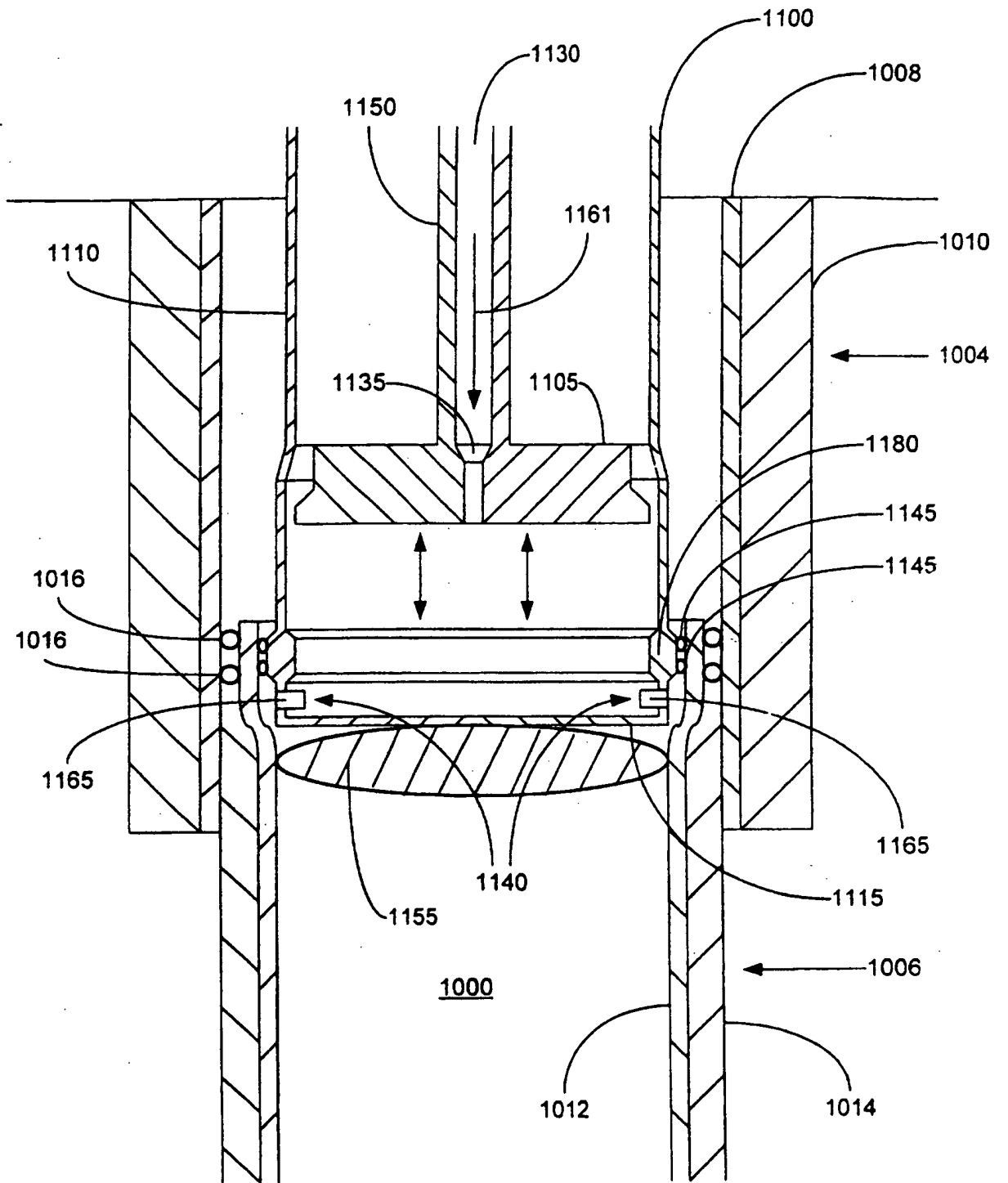

FIGURE 10e

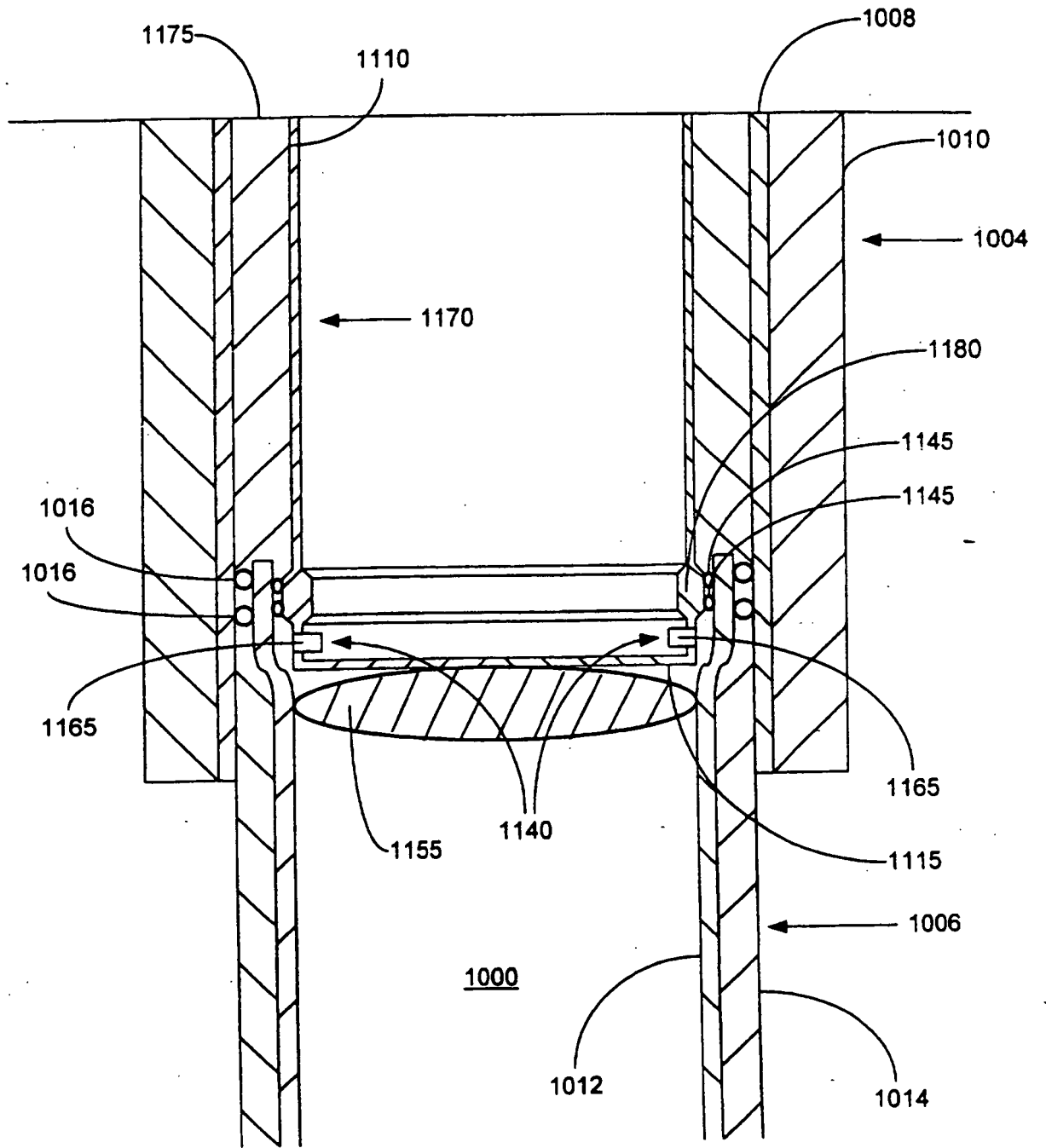

FIGURE 10f

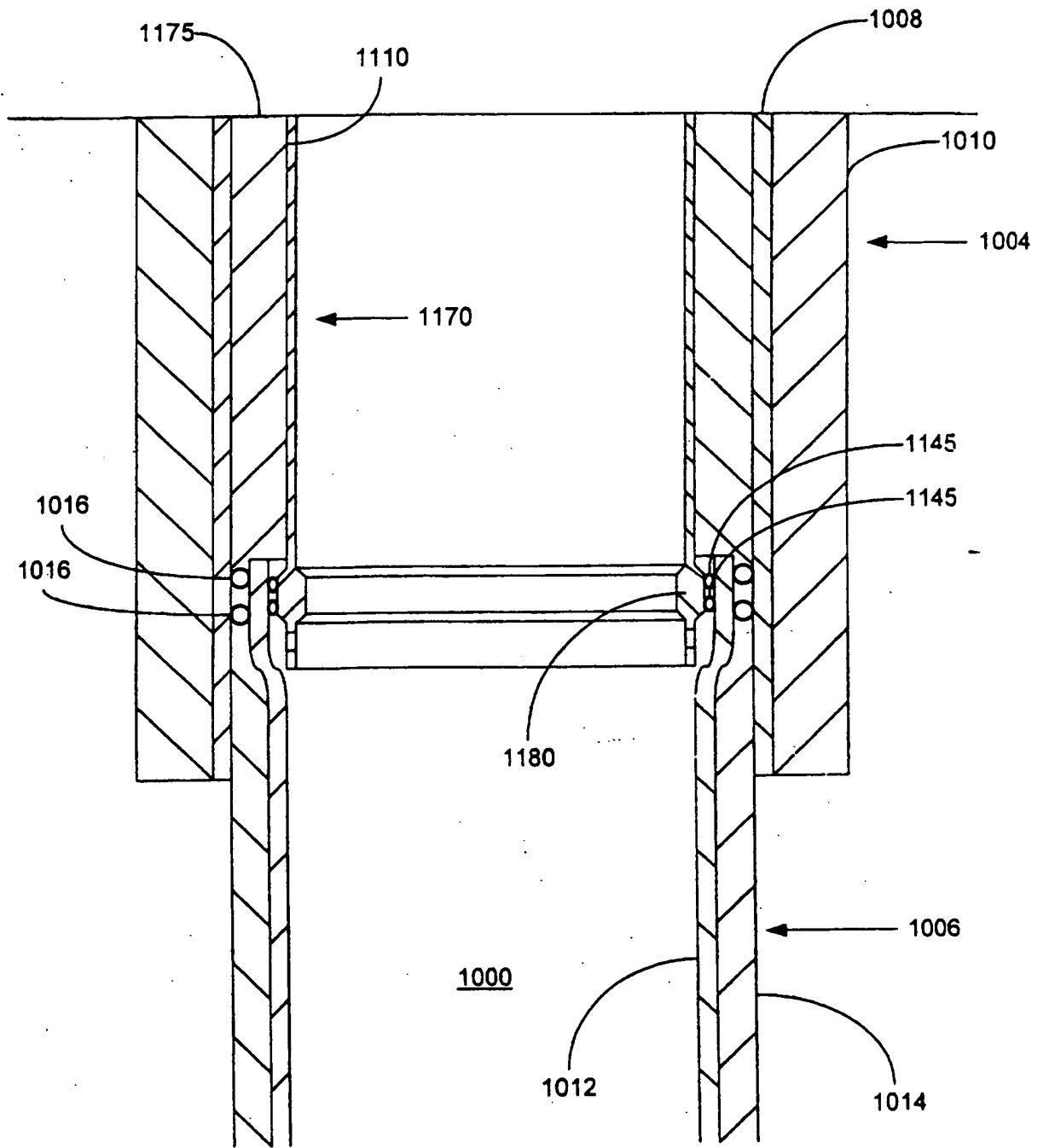

FIGURE 10g

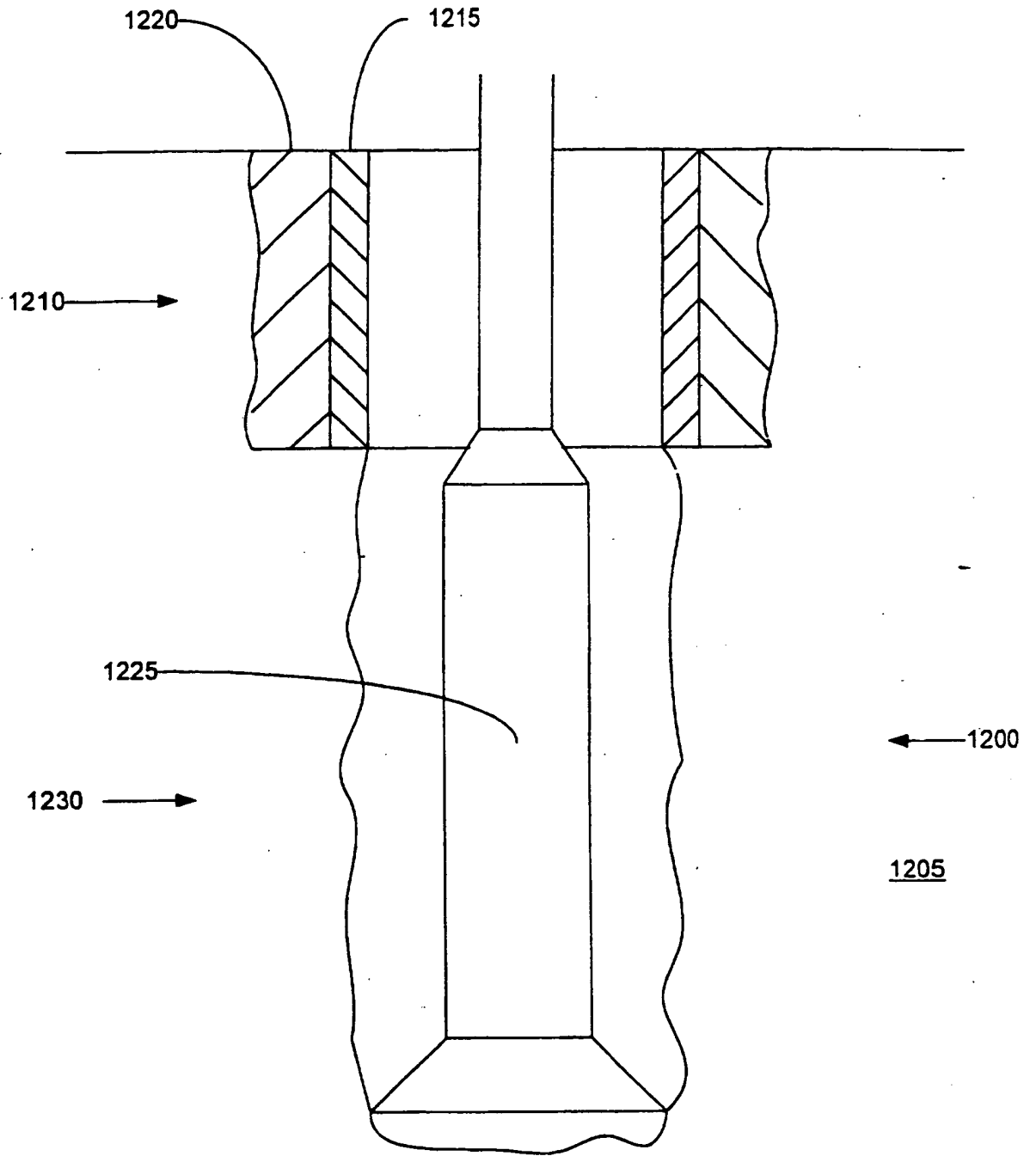

FIGURE 11a

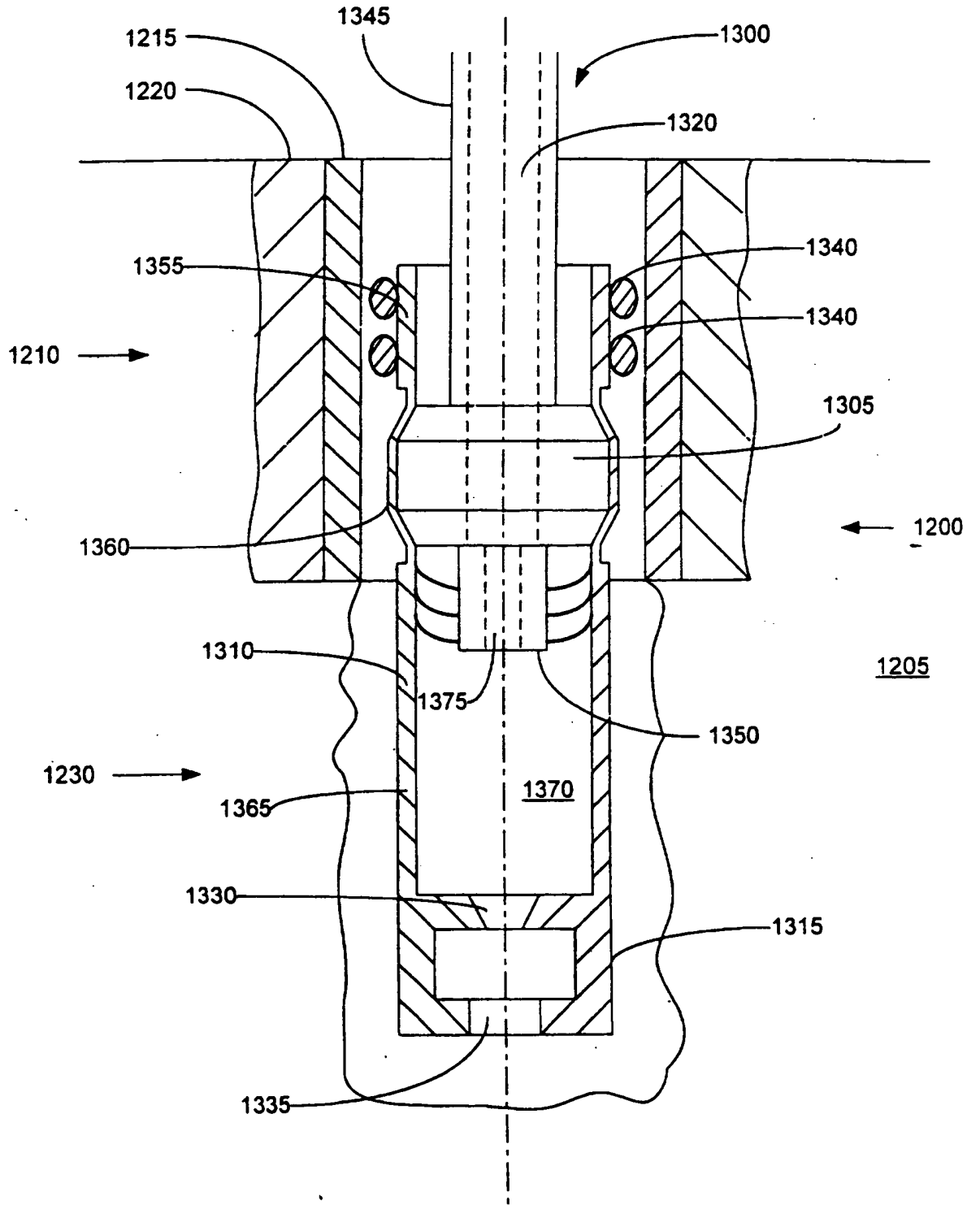

FIGURE 11b

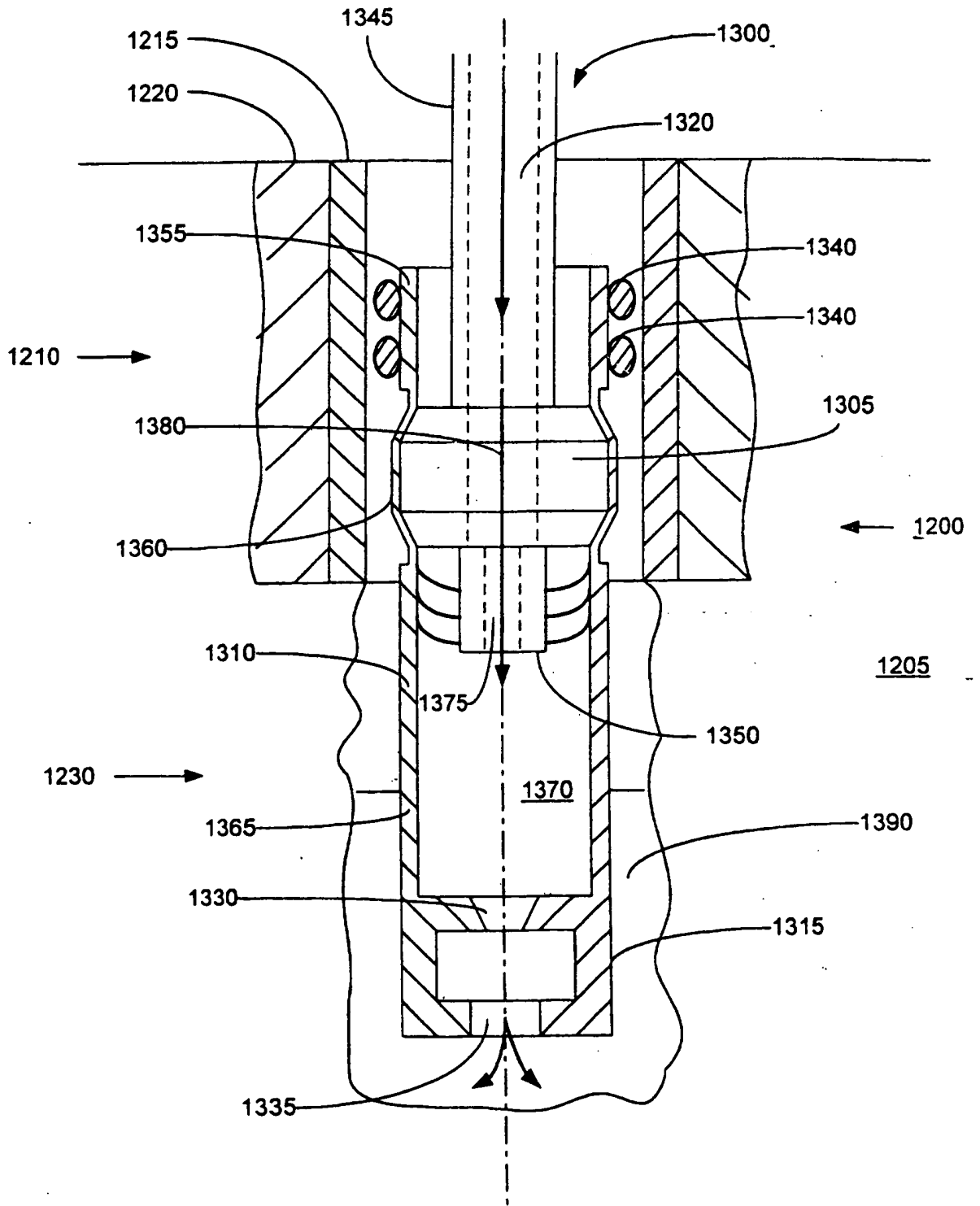

FIGURE 11c

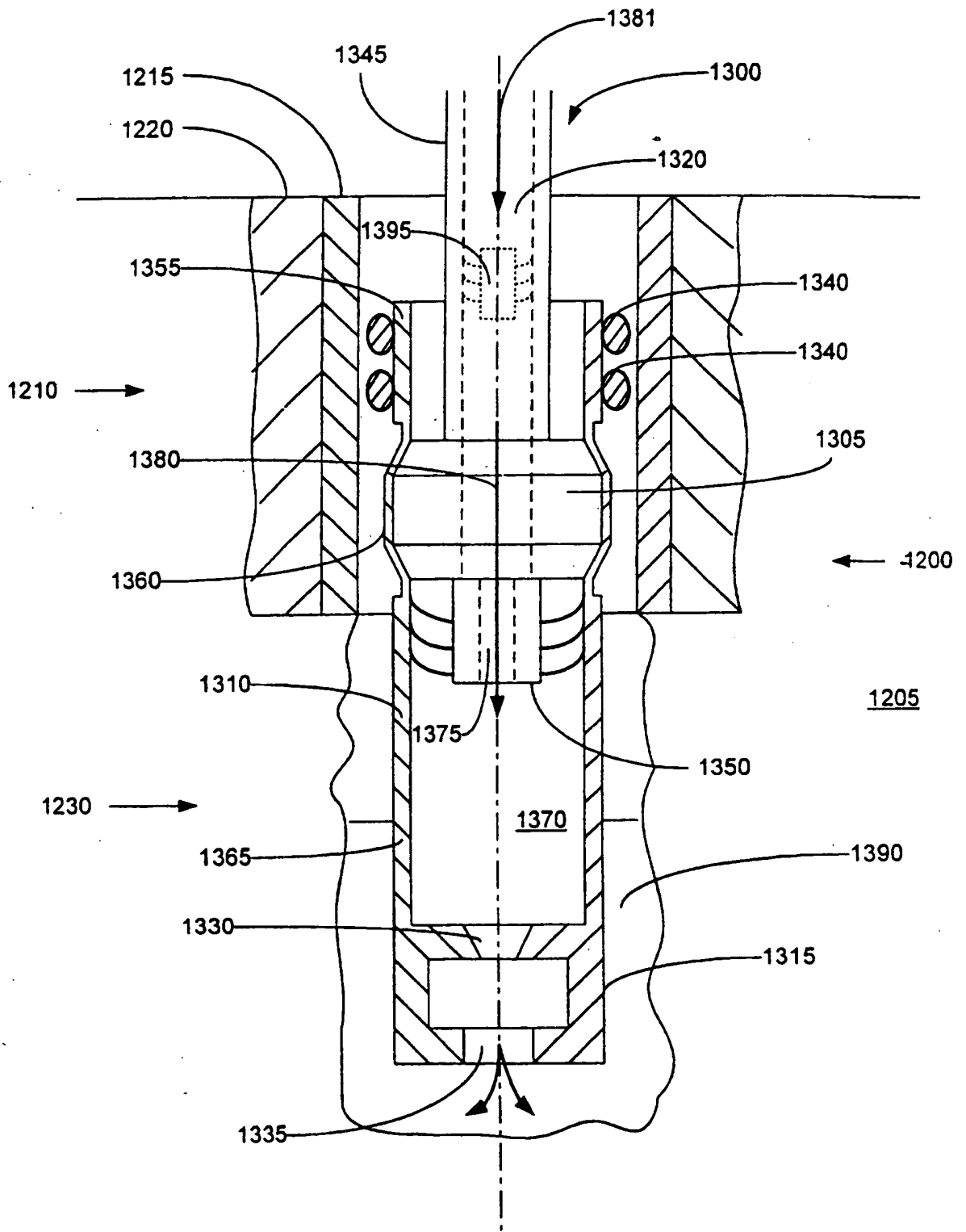

FIGURE 11d

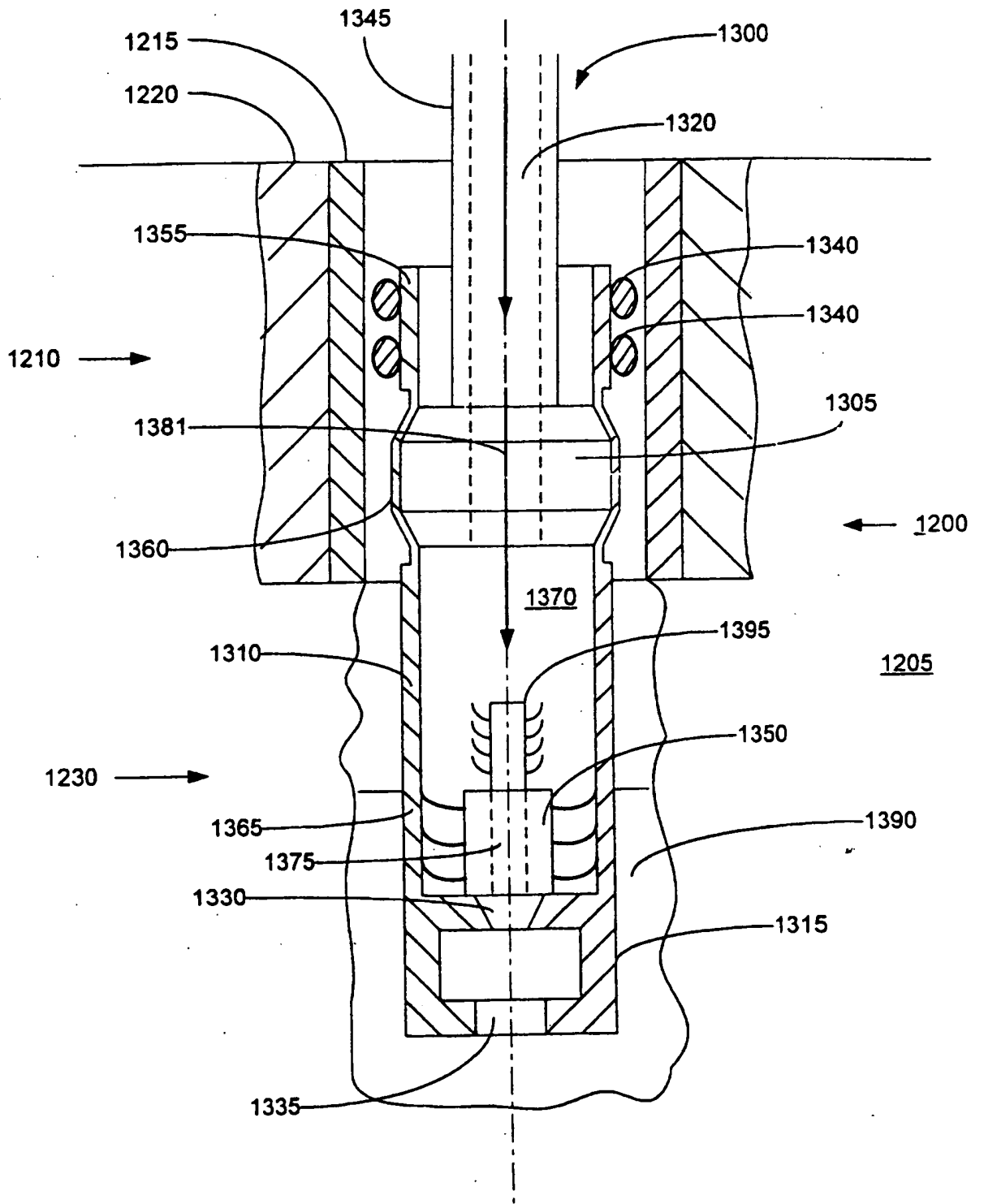

FIGURE 11e

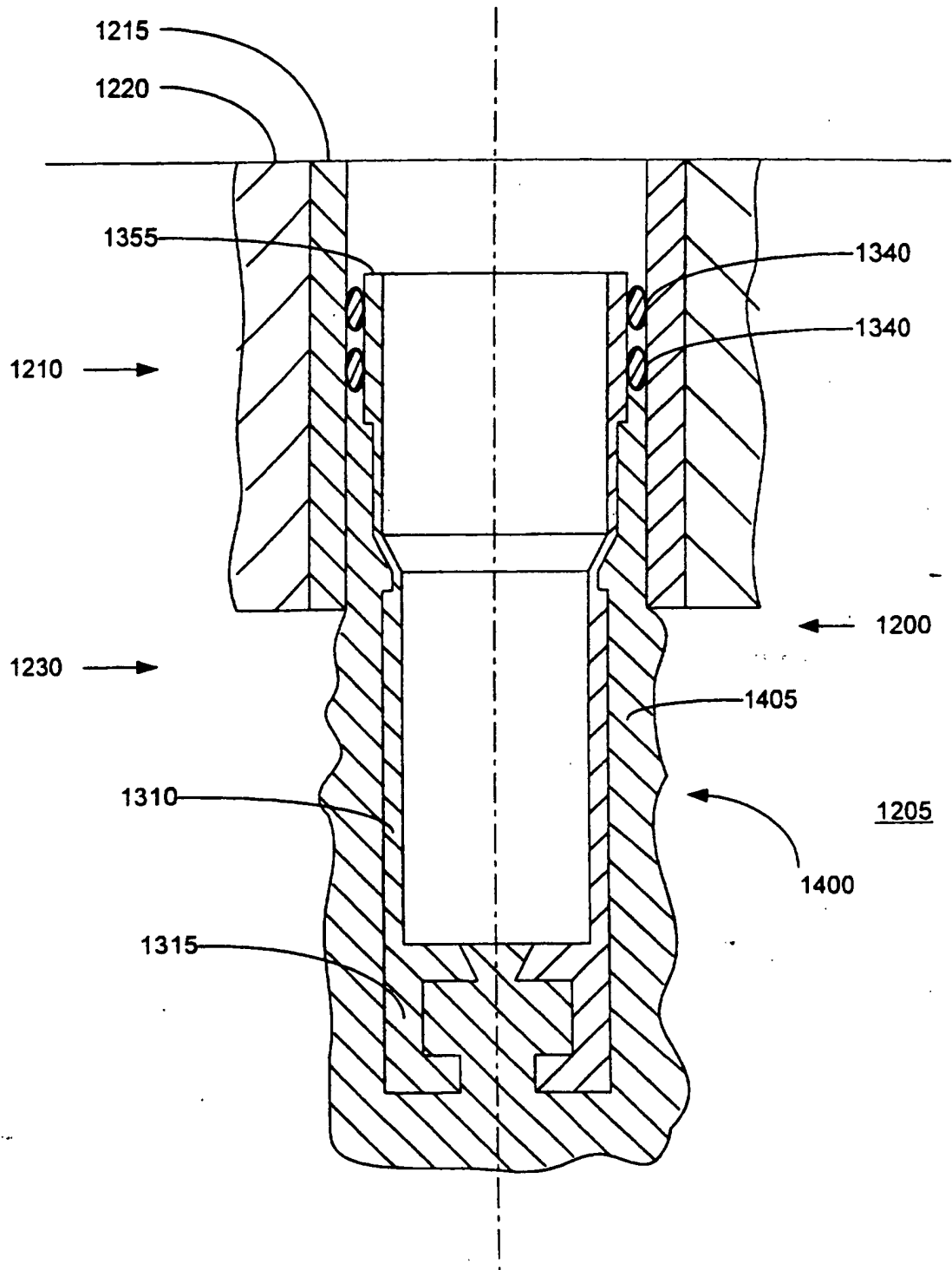

FIGURE 11f

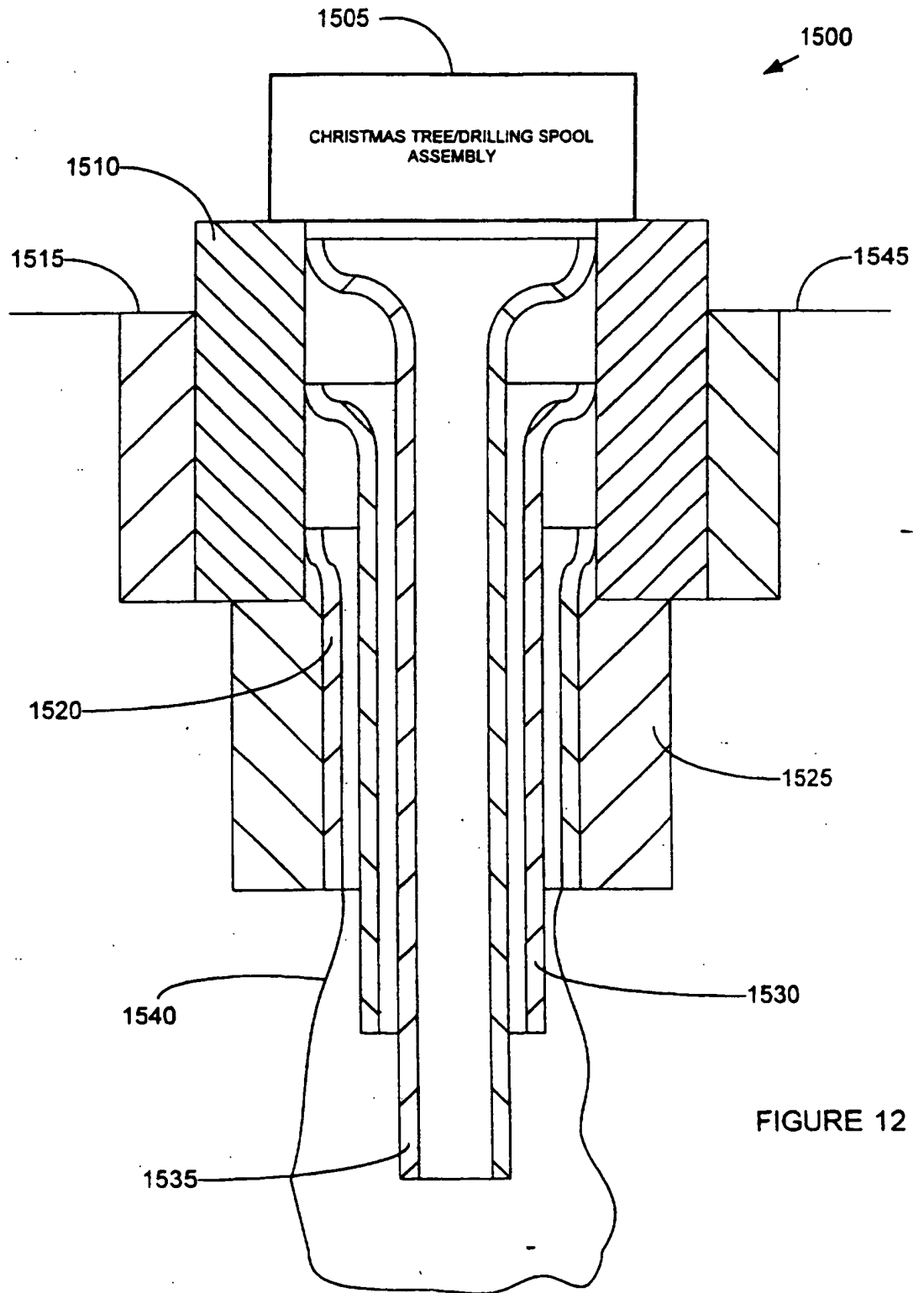

FIGURE 12

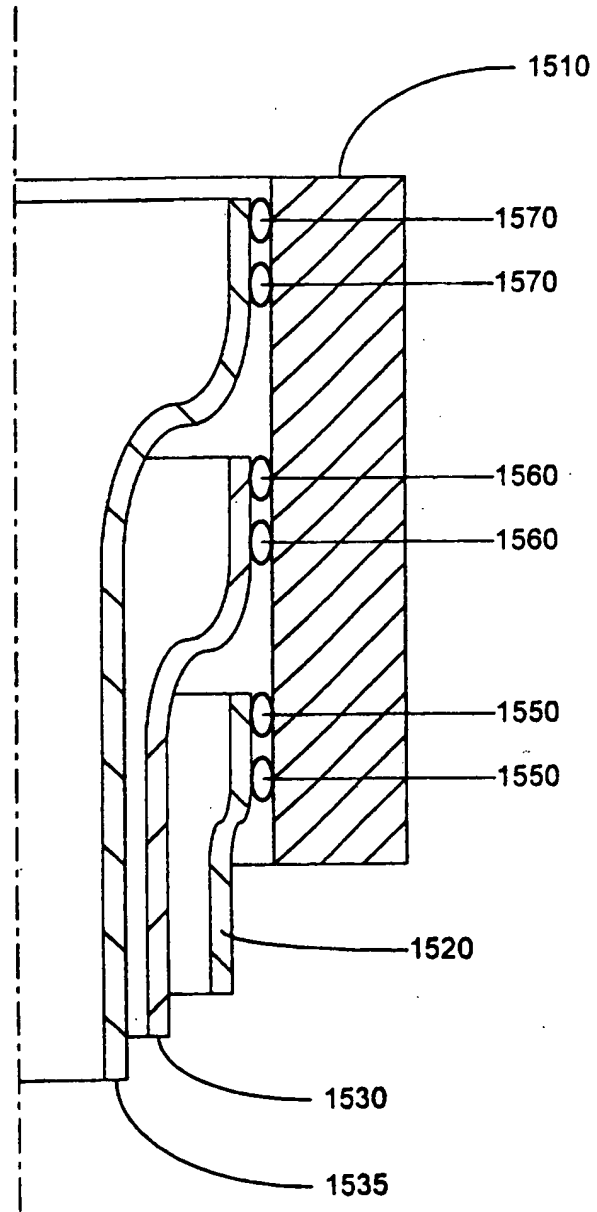

FIGURE 13

WELLHEAD**Backgr und of the Invention**

This invention relates generally to wellbore casings, and in particular to wellbore casings that are formed using expandable tubing.

5 Conventionally, when a wellbore is created, a number of casings are installed in the borehole to prevent collapse of the borehole wall and to prevent undesired outflow of drilling fluid into the formation or inflow of fluid from the formation into the borehole. The borehole is drilled in intervals whereby a casing which is to be installed in a lower borehole interval is lowered through a
10 previously installed casing of an upper borehole interval. As a consequence of this procedure the casing of the lower interval is of smaller diameter than the casing of the upper interval. Thus, the casings are in a nested arrangement with casing diameters decreasing in downward direction. Cement annuli are provided between the outer surfaces of the casings and the borehole wall to seal
15 the casings from the borehole wall. As a consequence of this nested arrangement a relatively large borehole diameter is required at the upper part of the wellbore. Such a large borehole diameter involves increased costs due to heavy casing handling equipment, large drill bits and increased volumes of drilling fluid and drill cuttings. Moreover, increased drilling rig time is
20 involved due to required cement pumping, cement hardening, required equipment changes due to large variations in hole diameters drilled in the course of the well, and the large volume of cuttings drilled and removed.

Conventionally, at the surface end of the wellbore, a wellhead is formed that typically includes a surface casing, a number of production and/or drilling
25 spools, valving, and a Christmas tree. Typically the wellhead further includes a concentric arrangements of casings including a production casing and one or more intermediate casings. The casings are typically supported using load bearing slips positioned above the ground. The conventional design and construction of wellheads is expensive and complex.

30 The present invention is directed to overcoming one or more of the limitations of the existing procedures for forming wellbores and wellheads.

Summary of the Invention

According to one aspect of the present invention, a method of forming a wellbore casing is provided that includes installing a tubular liner and a mandrel in the borehole, injecting fluidic material into the borehole, and
5 radially expanding the liner in the borehole by extruding the liner off of the mandrel.

According to another aspect of the present invention, a method of forming a wellbore casing is provided that includes drilling out a new section of the borehole adjacent to the already existing casing. A tubular liner and a
10 mandrel are then placed into the new section of the borehole with the tubular liner overlapping an already existing casing. A hardenable fluidic sealing material is injected into an annular region between the tubular liner and the new section of the borehole. The annular region between the tubular liner and the new section of the borehole is then fluidically isolated from an interior region
15 of the tubular liner below the mandrel. A non hardenable fluidic material is then injected into the interior region of the tubular liner below the mandrel. The tubular liner is extruded off of the mandrel. The overlap between the tubular liner and the already existing casing is sealed. The tubular liner is supported by overlap with the already existing casing. The mandrel is removed
20 from the borehole. The integrity of the seal of the overlap between the tubular liner and the already existing casing is tested. At least a portion of the second quantity of the hardenable fluidic sealing material is removed from the interior of the tubular liner. The remaining portions of the fluidic hardenable fluidic sealing material are cured. At least a portion of cured fluidic hardenable sealing
25 material within the tubular liner is removed.

According to another aspect of the present invention, an apparatus for expanding a tubular member is provided that includes a support member, a mandrel, a tubular member, and a shoe. The support member includes a first fluid passage. The mandrel is coupled to the support member and includes a
30 second fluid passage. The tubular member is coupled to the mandrel. The shoe is coupled to the tubular liner and includes a third fluid passage. The first, second and third fluid passages are operably coupled.

According to another aspect of the present invention, an apparatus for expanding a tubular member is provided that includes a support member, an expandable mandrel, a tubular member, a shoe, and at least one sealing member. The support member includes a first fluid passage, a second fluid
5 passage, and a flow control valve coupled to the first and second fluid passages. The expandable mandrel is coupled to the support member and includes a third fluid passage. The tubular member is coupled to the mandrel and includes one or more sealing elements. The shoe is coupled to the tubular member and includes a fourth fluid passage. The at least one sealing member is adapted to
10 prevent the entry of foreign material into an interior region of the tubular member.

According to another aspect of the present invention, a method of joining a second tubular member to a first tubular member, the first tubular member having an inner diameter greater than an outer diameter of the second tubular
15 member, is provided that includes positioning a mandrel within an interior region of the second tubular member. A portion of an interior region of the second tubular member is pressurized and the second tubular member is extruded off of the mandrel into engagement with the first tubular member.

According to another aspect of the present invention, a tubular liner is
20 provided that includes an annular member having one or more sealing members at an end portion of the annular member, and one or more pressure relief passages at an end portion of the annular member.

According to another aspect of the present invention, a wellbore casing is provided that includes a tubular liner and an annular body of a cured fluidic
25 sealing material. The tubular liner is formed by the process of extruding the tubular liner off of a mandrel.

According to another aspect of the present invention, a tie-back liner for lining an existing wellbore casing is provided that includes a tubular liner and an annular body of cured fluidic sealing material. The tubular liner is formed
30 by the process of extruding the tubular liner off of a mandrel. The annular body of a cured fluidic sealing material is coupled to the tubular liner.

According to another aspect of the present invention, an apparatus for expanding a tubular member is provided that includes a support member, a mandrel, a tubular member and a shoe. The support member includes a first fluid passage. The mandrel is coupled to the support member. The mandrel
5 includes a second fluid passage operably coupled to the first fluid passage, an interior portion, and an exterior portion. The interior portion of the mandrel is drillable. The tubular member is coupled to the mandrel. The shoe is coupled to the tubular member. The shoe includes a third fluid passage operably coupled to the second fluid passage, an interior portion, and an exterior portion.
10 The interior portion of the shoe is drillable.

According to another aspect of the present invention, a wellhead is provided that includes an outer casing and a plurality of concentric inner casings coupled to the outer casing. Each inner casing is supported by contact pressure between an outer surface of the inner casing and an inner surface of
15 the outer casing.

According to another aspect of the present invention, a wellhead is provided that include an outer casing at least partially positioned within a wellbore and a plurality of substantially concentric inner casings coupled to the interior surface of the outer casing. One or more of the inner casings are
20 coupled to the outer casing by expanding one or more of the inner casings into contact with at least a portion of the interior surface of the outer casing.

According to another aspect of the present invention, a method of forming a wellhead is provided that includes drilling a wellbore. An outer casing is positioned at least partially within an upper portion of the wellbore. A
25 first tubular member is positioned within the outer casing. At least a portion of the first tubular member is expanded into contact with an interior surface of the outer casing. A second tubular member is positioned within the outer casing and the first tubular member. At least a portion of the second tubular member is expanded into contact with an interior portion of the outer casing.

30 According to another aspect of the present invention, an apparatus is provided that includes an outer tubular member, and a plurality of substantially concentric and overlapping inner tubular members coupled to the

FIG. 8 is a fragmentary cross-sectional illustration of the placement of an expanded tubular member within another tubular member.

FIG. 9 is a cross-sectional illustration of a preferred embodiment of an apparatus for forming a casing including a drillable mandrel and shoe.

5 FIG. 9a is another cross-sectional illustration of the apparatus of FIG. 9.

FIG. 9b is another cross-sectional illustration of the apparatus of FIG. 9.

FIG. 9c is another cross-sectional illustration of the apparatus of FIG. 9.

FIG. 10a is a cross-sectional illustration of a wellbore including a pair of adjacent overlapping casings.

10 FIG. 10b is a cross-sectional illustration of an apparatus and method for creating a tie-back liner using an expandible tubular member.

FIG. 10c is a cross-sectional illustration of the pumping of a fluidic sealing material into the annular region between the tubular member and the existing casing.

15 FIG. 10d is a cross-sectional illustration of the pressurizing of the interior of the tubular member below the mandrel.

FIG. 10e is a cross-sectional illustration of the extrusion of the tubular member off of the mandrel.

20 FIG. 10f is a cross-sectional illustration of the tie-back liner before drilling out the shoe and packer.

FIG. 10g is a cross-sectional illustration of the completed tie-back liner created using an expandible tubular member.

FIG. 11a is a fragmentary cross-sectional view illustrating the drilling of a new section of a well borehole.

25 FIG. 11b is a fragmentary cross-sectional view illustrating the placement of an embodiment of an apparatus for hanging a tubular liner within the new section of the well borehole.

FIG. 11c is a fragmentary cross-sectional view illustrating the injection of a first quantity of a fluidic material into the new section of the well borehole.

30 FIG. 11d is a fragmentary cross-sectional view illustrating the introduction of a wiper dart into the new section of the well borehole.

FIG. 11e is a fragmentary cross-sectional view illustrating the injection of a second quantity of a fluidic material into the new section of the well borehole.

FIG. 11f is a fragmentary cross-sectional view illustrating the completion of the tubular liner.

5 FIG. 12 is a cross-sectional illustration of a preferred embodiment of a wellhead system utilizing expandable tubular members.

FIG. 13 is a partial cross-sectional illustration of a preferred embodiment of the wellhead system of FIG. 12.

Detailed Description of the Illustrative Embodiments

10 An apparatus and method for forming a wellbore casing within a subterranean formation is provided. The apparatus and method permits a wellbore casing to be formed in a subterranean formation by placing a tubular member and a mandrel in a new section of a wellbore, and then extruding the tubular member off of the mandrel by pressurizing an interior portion of the
15 tubular member. The apparatus and method further permits adjacent tubular members in the wellbore to be joined using an overlapping joint that prevents fluid and or gas passage. The apparatus and method further permits a new tubular member to be supported by an existing tubular member by expanding the new tubular member into engagement with the existing tubular member.
20 The apparatus and method further minimizes the reduction in the hole size of the wellbore casing necessitated by the addition of new sections of wellbore casing.

An apparatus and method for forming a tie-back liner using an expandable tubular member is also provided. The apparatus and method
25 permits a tie-back liner to be created by extruding a tubular member off of a mandrel by pressurizing and interior portion of the tubular member. In this manner, a tie-back liner is produced. The apparatus and method further permits adjacent tubular members in the wellbore to be joined using an overlapping joint that prevents fluid and/or gas passage. The apparatus and
30 method further permits a new tubular member to be supported by an existing tubular member by expanding the new tubular member into engagement with the existing tubular member.

An apparatus and method for expanding a tubular member is also provided that includes an expandable tubular member, mandrel and a shoe. In a preferred embodiment, the interior portions of the apparatus is composed of materials that permit the interior portions to be removed using a conventional
5 drilling apparatus. In this manner, in the event of a malfunction in a downhole region, the apparatus may be easily removed.

An apparatus and method for hanging an expandable tubular liner in a wellbore is also provided. The apparatus and method permit a tubular liner to be attached to an existing section of casing. The apparatus and method further
10 have application to the joining of tubular members in general.

An apparatus and method for forming a wellhead system is also provided. The apparatus and method permit a wellhead to be formed including a number of expandable tubular members positioned in a concentric arrangement. The wellhead preferably includes an outer casing that supports a plurality of
15 concentric casings using contact pressure between the inner casings and the outer casing. The resulting wellhead system eliminates many of the spools conventionally required, reduces the height of the Christmas tree facilitating servicing, lowers the load bearing areas of the wellhead resulting in a more stable system, and eliminates costly and expensive hanger systems.

20 Referring initially to Figs. 1-5, an embodiment of an apparatus and method for forming a wellbore casing within a subterranean formation will now be described. As illustrated in Fig. 1, a wellbore 100 is positioned in a subterranean formation 105. The wellbore 100 includes an existing cased section 110 having a tubular casing 115 and an annular outer layer of cement
25 120.

In order to extend the wellbore 100 into the subterranean formation 105, a drill string 125 is used in a well known manner to drill out material from the subterranean formation 105 to form a new section 130.

As illustrated in Fig. 2, an apparatus 200 for forming a wellbore casing in
30 a subterranean formation is then positioned in the new section 130 of the wellbore 100. The apparatus 200 preferably includes an expandable mandrel or pig 205, a tubular member 210, a shoe 215, a lower cup seal 220, an upper cup

seal 225, a fluid passage 230, a fluid passage 235, a fluid passage 240, seals 245, and a support member 250.

The expandable mandrel 205 is coupled to and supported by the support member 250. The expandable mandrel 205 is preferably adapted to controllably expand in a radial direction. The expandable mandrel 205 may comprise any number of conventional commercially available expandable mandrels modified in accordance with the teachings of the present disclosure. In a preferred embodiment, the expandable mandrel 205 comprises a hydraulic expansion tool as disclosed in U.S. Patent No. 5,348,095, the contents of which are incorporated herein by reference, modified in accordance with the teachings of the present disclosure.

The tubular member 210 is supported by the expandable mandrel 205. The tubular member 210 is expanded in the radial direction and extruded off of the expandable mandrel 205. The tubular member 210 may be fabricated from any number of conventional commercially available materials such as, for example, Oilfield Country Tubular Goods (OCTG), 13 chromium steel tubing/casing, or plastic tubing/casing. In a preferred embodiment, the tubular member 210 is fabricated from OCTG in order to maximize strength after expansion. The inner and outer diameters of the tubular member 210 may range, for example, from approximately 0.75 to 47 inches and 1.05 to 48 inches, respectively. In a preferred embodiment, the inner and outer diameters of the tubular member 210 range from about 3 to 15.5 inches and 3.5 to 16 inches, respectively in order to optimally provide minimal telescoping effect in the most commonly drilled wellbore sizes. The tubular member 210 preferably comprises a solid member.

In a preferred embodiment, the end portion 260 of the tubular member 210 is slotted, perforated, or otherwise modified to catch or slow down the mandrel 205 when it completes the extrusion of tubular member 210. In a preferred embodiment, the length of the tubular member 210 is limited to minimize the possibility of buckling. For typical tubular member 210 materials, the length of the tubular member 210 is preferably limited to between about 40 to 20,000 feet in length.

The shoe 215 is coupled to the expandable mandrel 205 and the tubular member 210. The shoe 215 includes fluid passage 240. The shoe 215 may comprise any number of conventional commercially available shoes such as, for example, Super Seal II float shoe, Super Seal II Down-Jet float shoe or a guide shoe with a sealing sleeve for a latch down plug modified in accordance with the teachings of the present disclosure. In a preferred embodiment, the shoe 215 comprises an aluminum down-jet guide shoe with a sealing sleeve for a latch-down plug available from Halliburton Energy Services in Dallas, TX, modified in accordance with the teachings of the present disclosure, in order to optimally guide the tubular member 210 in the wellbore, optimally provide an adequate seal between the interior and exterior diameters of the overlapping joint between the tubular members, and to optimally allow the complete drill out of the shoe and plug after the completion of the cementing and expansion operations.

In a preferred embodiment, the shoe 215 includes one or more through and side outlet ports in fluidic communication with the fluid passage 240. In this manner, the shoe 215 optimally injects hardenable fluidic sealing material into the region outside the shoe 215 and tubular member 210. In a preferred embodiment, the shoe 215 includes the fluid passage 240 having an inlet geometry that can receive a dart and/or a ball sealing member. In this manner, the fluid passage 240 can be optimally sealed off by introducing a plug, dart and/or ball sealing elements into the fluid passage 230.

The lower cup seal 220 is coupled to and supported by the support member 250. The lower cup seal 220 prevents foreign materials from entering the interior region of the tubular member 210 adjacent to the expandable mandrel 205. The lower cup seal 220 may comprise any number of conventional commercially available cup seals such as, for example, TP cups, or Selective Injection Packer (SIP) cups modified in accordance with the teachings of the present disclosure. In a preferred embodiment, the lower cup seal 220 comprises a SIP cup seal, available from Halliburton Energy Services in Dallas, TX in order to optimally block foreign material and contain a body of lubricant.

The upper cup seal 225 is coupled to and supported by the support member 250. The upper cup seal 225 prevents foreign materials from entering the interior region of the tubular member 210. The upper cup seal 225 may comprise any number of conventional commercially available cup seals such as, 5 for example, TP cups or SIP cups modified in accordance with the teachings of the present disclosure. In a preferred embodiment, the upper cup seal 225 comprises a SIP cup, available from Halliburton Energy Services in Dallas, TX in order to optimally block the entry of foreign materials and contain a body of lubricant.

10 The fluid passage 230 permits fluidic materials to be transported to and from the interior region of the tubular member 210 below the expandable mandrel 205. The fluid passage 230 is coupled to and positioned within the support member 250 and the expandable mandrel 205. The fluid passage 230 preferably extends from a position adjacent to the surface to the bottom of the 15 expandable mandrel 205. The fluid passage 230 is preferably positioned along a centerline of the apparatus 200.

The fluid passage 230 is preferably selected, in the casing running mode of operation, to transport materials such as drilling mud or formation fluids at flow rates and pressures ranging from about 0 to 3,000 gallons/minute and 0 to 20 9,000 psi in order to minimize drag on the tubular member being run and to minimize surge pressures exerted on the wellbore which could cause a loss of wellbore fluids and lead to hole collapse.

The fluid passage 235 permits fluidic materials to be released from the fluid passage 230. In this manner, during placement of the apparatus 200 25 within the new section 130 of the wellbore 100, fluidic materials 255 forced up the fluid passage 230 can be released into the wellbore 100 above the tubular member 210 thereby minimizing surge pressures on the wellbore section 130. The fluid passage 235 is coupled to and positioned within the support member 250. The fluid passage is further fluidically coupled to the fluid passage 230.

30 The fluid passage 235 preferably includes a control valve for controllably opening and closing the fluid passage 235. In a preferred embodiment, the control valve is pressure activated in order to controllably minimize surge

pressures. The fluid passage 235 is preferably positioned substantially orthogonal to the centerline of the apparatus 200.

The fluid passage 235 is preferably selected to convey fluidic materials at flow rates and pressures ranging from about 0 to 3,000 gallons/minute and 0 to 9,000 psi in order to reduce the drag on the apparatus 200 during insertion into the new section 130 of the wellbore 100 and to minimize surge pressures on the new wellbore section 130.

The fluid passage 240 permits fluidic materials to be transported to and from the region exterior to the tubular member 210 and shoe 215. The fluid passage 240 is coupled to and positioned within the shoe 215 in fluidic communication with the interior region of the tubular member 210 below the expandable mandrel 205. The fluid passage 240 preferably has a cross-sectional shape that permits a plug, or other similar device, to be placed in fluid passage 240 to thereby block further passage of fluidic materials. In this manner, the interior region of the tubular member 210 below the expandable mandrel 205 can be fluidically isolated from the region exterior to the tubular member 210. This permits the interior region of the tubular member 210 below the expandable mandrel 205 to be pressurized. The fluid passage 240 is preferably positioned substantially along the centerline of the apparatus 200.

The fluid passage 240 is preferably selected to convey materials such as cement, drilling mud or epoxies at flow rates and pressures ranging from about 0 to 3,000 gallons/minute and 0 to 9,000 psi in order to optimally fill the annular region between the tubular member 210 and the new section 130 of the wellbore 100 with fluidic materials. In a preferred embodiment, the fluid passage 240 includes an inlet geometry that can receive a dart and/or a ball sealing member. In this manner, the fluid passage 240 can be sealed off by introducing a plug, dart and/or ball sealing elements into the fluid passage 230.

The seals 245 are coupled to and supported by an end portion 260 of the tubular member 210. The seals 245 are further positioned on an outer surface 265 of the end portion 260 of the tubular member 210. The seals 245 permit the overlapping joint between the end portion 270 of the casing 115 and the portion 260 of the tubular member 210 to be fluidically sealed. The seals 245

may comprise any number of conventional commercially available seals such as, for example, lead, rubber, Teflon, or epoxy seals modified in accordance with the teachings of the present disclosure. In a preferred embodiment, the seals 245 are molded from Stratalock epoxy available from Halliburton Energy Services in Dallas, TX in order to optimally provide a load bearing interference fit between the end 260 of the tubular member 210 and the end 270 of the existing casing 115.

In a preferred embodiment, the seals 245 are selected to optimally provide a sufficient frictional force to support the expanded tubular member 210 from the existing casing 115. In a preferred embodiment, the frictional force optimally provided by the seals 245 ranges from about 1,000 to 1,000,000 lbf in order to optimally support the expanded tubular member 210.

The support member 250 is coupled to the expandable mandrel 205, tubular member 210, shoe 215, and seals 220 and 225. The support member 250 preferably comprises an annular member having sufficient strength to carry the apparatus 200 into the new section 130 of the wellbore 100. In a preferred embodiment, the support member 250 further includes one or more conventional centralizers (not illustrated) to help stabilize the apparatus 200.

In a preferred embodiment, a quantity of lubricant 275 is provided in the annular region above the expandable mandrel 205 within the interior of the tubular member 210. In this manner, the extrusion of the tubular member 210 off of the expandable mandrel 205 is facilitated. The lubricant 275 may comprise any number of conventional commercially available lubricants such as, for example, Lubriplate, chlorine based lubricants, oil based lubricants or Climax 1500 Antisieze (3100). In a preferred embodiment, the lubricant 275 comprises Climax 1500 Antisieze (3100) available from Climax Lubricants and Equipment Co. in Houston, TX in order to optimally provide optimum lubrication to facilitate the expansion process.

In a preferred embodiment, the support member 250 is thoroughly cleaned prior to assembly to the remaining portions of the apparatus 200. In this manner, the introduction of foreign material into the apparatus 200 is

minimized. This minimizes the possibility of foreign material clogging the various flow passages and valves of the apparatus 200.

In a preferred embodiment, before or after positioning the apparatus 200 within the new section 130 of the wellbore 100, a couple of wellbore volumes are 5 circulated in order to ensure that no foreign materials are located within the wellbore 100 that might clog up the various flow passages and valves of the apparatus 200 and to ensure that no foreign material interferes with the expansion process.

As illustrated in Fig. 3, the fluid passage 235 is then closed and a 10 hardenable fluidic sealing material 305 is then pumped from a surface location into the fluid passage 230. The material 305 then passes from the fluid passage 230 into the interior region 310 of the tubular member 210 below the expandable mandrel 205. The material 305 then passes from the interior region 310 into the fluid passage 240. The material 305 then exits the apparatus 200 15 and fills the annular region 315 between the exterior of the tubular member 210 and the interior wall of the new section 130 of the wellbore 100. Continued pumping of the material 305 causes the material 305 to fill up at least a portion of the annular region 315.

The material 305 is preferably pumped into the annular region 315 at 20 pressures and flow rates ranging, for example, from about 0 to 5000 psi and 0 to 1,500 gallons/min, respectively. The optimum flow rate and operating pressures vary as a function of the casing and wellbore sizes, wellbore section length, available pumping equipment, and fluid properties of the fluidic material being pumped. The optimum flow rate and operating pressure are 25 preferably determined using conventional empirical methods.

The hardenable fluidic sealing material 305 may comprise any number of conventional commercially available hardenable fluidic sealing materials such as, for example, slag mix, cement or epoxy. In a preferred embodiment, the hardenable fluidic sealing material 305 comprises a blended cement prepared 30 specifically for the particular well section being drilled from Halliburton Energy Services in Dallas, TX in order to provide optimal support for tubular member 210 while also maintaining optimum flow characteristics, so as to minimize

difficulties during the displacement of cement in the annular region 315. The optimum blend of the blended cement is preferably determined using conventional empirical methods.

The annular region 315 preferably is filled with the material 305 in sufficient quantities to ensure that, upon radial expansion of the tubular member 210, the annular region 315 of the new section 130 of the wellbore 100 will be filled with material 305.

In a particularly preferred embodiment, as illustrated in Fig. 3a, the wall thickness and/or the outer diameter of the tubular member 210 is reduced in the region adjacent to the mandrel 205 in order optimally permit placement of the apparatus 200 in positions in the wellbore with tight clearances. Furthermore, in this manner, the initiation of the radial expansion of the tubular member 210 during the extrusion process is optimally facilitated.

As illustrated in Fig. 4, once the annular region 315 has been adequately filled with material 305, a plug 405, or other similar device, is introduced into the fluid passage 240 thereby fluidically isolating the interior region 310 from the annular region 315. In a preferred embodiment, a non-hardenable fluidic material 306 is then pumped into the interior region 310 causing the interior region to pressurize. In this manner, the interior of the expanded tubular member 210 will not contain significant amounts of cured material 305. This reduces and simplifies the cost of the entire process. Alternatively, the material 305 may be used during this phase of the process.

Once the interior region 310 becomes sufficiently pressurized, the tubular member 210 is extruded off of the expandable mandrel 205. During the extrusion process, the expandable mandrel 205 may be raised out of the expanded portion of the tubular member 210. In a preferred embodiment, during the extrusion process, the mandrel 205 is raised at approximately the same rate as the tubular member 210 is expanded in order to keep the tubular member 210 stationary relative to the new wellbore section 130. In an alternative preferred embodiment, the extrusion process is commenced with the tubular member 210 positioned above the bottom of the new wellbore section 130, keeping the mandrel 205 stationary, and allowing the tubular member 210

to extrude off of the mandrel 205 and fall down the new wellbore section 130 under the force of gravity.

The plug 405 is preferably placed into the fluid passage 240 by introducing the plug 405 into the fluid passage 230 at a surface location in a conventional manner. The plug 405 preferably acts to fluidically isolate the hardenable fluidic sealing material 305 from the non hardenable fluidic material 306.

The plug 405 may comprise any number of conventional commercially available devices from plugging a fluid passage such as, for example, Multiple Stage Cementer (MSC) latch-down plug, Omega latch-down plug or three-wiper latch-down plug modified in accordance with the teachings of the present disclosure. In a preferred embodiment, the plug 405 comprises a MSC latch-down plug available from Halliburton Energy Services in Dallas, TX.

After placement of the plug 405 in the fluid passage 240, a non hardenable fluidic material 306 is preferably pumped into the interior region 310 at pressures and flow rates ranging, for example, from approximately 400 to 10,000 psi and 30 to 4,000 gallons/min. In this manner, the amount of hardenable fluidic sealing material within the interior 310 of the tubular member 210 is minimized. In a preferred embodiment, after placement of the plug 405 in the fluid passage 240, the non hardenable material 306 is preferably pumped into the interior region 310 at pressures and flow rates ranging from approximately 500 to 9,000 psi and 40 to 3,000 gallons/min in order to maximize the extrusion speed.

In a preferred embodiment, the apparatus 200 is adapted to minimize tensile, burst, and friction effects upon the tubular member 210 during the expansion process. These effects will be depend upon the geometry of the expansion mandrel 205, the material composition of the tubular member 210 and expansion mandrel 205, the inner diameter of the tubular member 210, the wall thickness of the tubular member 210, the type of lubricant, and the yield strength of the tubular member 210. In general, the thicker the wall thickness, the smaller the inner diameter, and the greater the yield strength of the tubular

member 210, then the greater the operating pressures required to extrude the tubular member 210 off of the mandrel 205.

For typical tubular members 210, the extrusion of the tubular member 210 off of the expandable mandrel will begin when the pressure of the interior 5 region 310 reaches, for example, approximately 500 to 9,000 psi.

During the extrusion process, the expandable mandrel 205 may be raised out of the expanded portion of the tubular member 210 at rates ranging, for example, from about 0 to 5 ft/sec. In a preferred embodiment, during the extrusion process, the expandable mandrel 205 is raised out of the expanded 10 portion of the tubular member 210 at rates ranging from about 0 to 2 ft/sec in order to minimize the time required for the expansion process while also permitting easy control of the expansion process.

When the end portion 260 of the tubular member 210 is extruded off of the expandable mandrel 205, the outer surface 265 of the end portion 260 of the 15 tubular member 210 will preferably contact the interior surface 410 of the end portion 270 of the casing 115 to form an fluid tight overlapping joint. The contact pressure of the overlapping joint may range, for example, from approximately 50 to 20,000 psi. In a preferred embodiment, the contact pressure of the overlapping joint ranges from approximately 400 to 10,000 psi in 20 order to provide optimum pressure to activate the annular sealing members 245 and optimally provide resistance to axial motion to accommodate typical tensile and compressive loads.

The overlapping joint between the section 410 of the existing casing 115 and the section 265 of the expanded tubular member 210 preferably provides a 25 gaseous and fluidic seal. In a particularly preferred embodiment, the sealing members 245 optimally provide a fluidic and gaseous seal in the overlapping joint.

In a preferred embodiment, the operating pressure and flow rate of the non hardenable fluidic material 306 is controllably ramped down when the 30 expandable mandrel 205 reaches the end portion 260 of the tubular member 210. In this manner, the sudden release of pressure caused by the complete extrusion of the tubular member 210 off of the expandable mandrel 205 can be

minimized. In a preferred embodiment, the operating pressure is reduced in a substantially linear fashion from 100% to about 10% during the end of the extrusion process beginning when the mandrel 205 is within about 5 feet from completion of the extrusion process.

5 Alternatively, or in combination, a shock absorber is provided in the support member 250 in order to absorb the shock caused by the sudden release of pressure. The shock absorber may comprise, for example, any conventional commercially available shock absorber adapted for use in wellbore operations.

10 Alternatively, or in combination, a mandrel catching structure is provided in the end portion 260 of the tubular member 210 in order to catch or at least decelerate the mandrel 205.

Once the extrusion process is completed, the expandable mandrel 205 is removed from the wellbore 100. In a preferred embodiment, either before or after the removal of the expandable mandrel 205, the integrity of the fluidic seal 15 of the overlapping joint between the upper portion 260 of the tubular member 210 and the lower portion 270 of the casing 115 is tested using conventional methods.

If the fluidic seal of the overlapping joint between the upper portion 260 of the tubular member 210 and the lower portion 270 of the casing 115 is 20 satisfactory, then any uncured portion of the material 305 within the expanded tubular member 210 is then removed in a conventional manner such as, for example, circulating the uncured material out of the interior of the expanded tubular member 210. The mandrel 205 is then pulled out of the wellbore section 130 and a drill bit or mill is used in combination with a conventional 25 drilling assembly 505 to drill out any hardened material 305 within the tubular member 210. The material 305 within the annular region 315 is then allowed to cure.

As illustrated in Fig. 5, preferably any remaining cured material 305 within the interior of the expanded tubular member 210 is then removed in a 30 conventional manner using a conventional drill string 505. The resulting new section of casing 510 includes the expanded tubular member 210 and an outer annular layer 515 of cured material 305. The bottom portion of the apparatus

200 comprising the shoe 215 and dart 405 may then be removed by drilling out the shoe 215 and dart 405 using conventional drilling methods.

In a preferred embodiment, as illustrated in Fig. 6, the upper portion 260 of the tubular member 210 includes one or more sealing members 605 and one or more pressure relief holes 610. In this manner, the overlapping joint between the lower portion 270 of the casing 115 and the upper portion 260 of the tubular member 210 is pressure-tight and the pressure on the interior and exterior surfaces of the tubular member 210 is equalized during the extrusion process.

10 In a preferred embodiment, the sealing members 605 are seated within recesses 615 formed in the outer surface 265 of the upper portion 260 of the tubular member 210. In an alternative preferred embodiment, the sealing members 605 are bonded or molded onto the outer surface 265 of the upper portion 260 of the tubular member 210. The pressure relief holes 610 are
15 preferably positioned in the last few feet of the tubular member 210. The pressure relief holes reduce the operating pressures required to expand the upper portion 260 of the tubular member 210. This reduction in required operating pressure in turn reduces the velocity of the mandrel 205 upon the completion of the extrusion process. This reduction in velocity in turn
20 minimizes the mechanical shock to the entire apparatus 200 upon the completion of the extrusion process.

Referring now to Fig. 7, a particularly preferred embodiment of an apparatus 700 for forming a casing within a wellbore preferably includes an expandable mandrel or pig 705, an expandable mandrel or pig container 710, a
25 tubular member 715, a float shoe 720, a lower cup seal 725, an upper cup seal 730, a fluid passage 735, a fluid passage 740, a support member 745, a body of lubricant 750, an overshot connection 755, another support member 760, and a stabilizer 765.

The expandable mandrel 705 is coupled to and supported by the support
30 member 745. The expandable mandrel 705 is further coupled to the expandable mandrel container 710. The expandable mandrel 705 is preferably adapted to controllably expand in a radial direction. The expandable mandrel 705 may

comprise any number of conventional commercially available expandable mandrels modified in accordance with the teachings of the present disclosure. In a preferred embodiment, the expandable mandrel 705 comprises a hydraulic expansion tool substantially as disclosed in U.S. Pat. No. 5,348,095, the contents of which are incorporated herein by reference, modified in accordance with the teachings of the present disclosure.

The expandable mandrel container 710 is coupled to and supported by the support member 745. The expandable mandrel container 710 is further coupled to the expandable mandrel 705. The expandable mandrel container 710 may be constructed from any number of conventional commercially available materials such as, for example, Oilfield Country Tubular Goods, stainless steel, titanium or high strength steels. In a preferred embodiment, the expandable mandrel container 710 is fabricated from material having a greater strength than the material from which the tubular member 715 is fabricated. In this manner, the container 710 can be fabricated from a tubular material having a thinner wall thickness than the tubular member 210. This permits the container 710 to pass through tight clearances thereby facilitating its placement within the wellbore.

In a preferred embodiment, once the expansion process begins, and the thicker, lower strength material of the tubular member 715 is expanded, the outside diameter of the tubular member 715 is greater than the outside diameter of the container 710.

The tubular member 715 is coupled to and supported by the expandable mandrel 705. The tubular member 715 is preferably expanded in the radial direction and extruded off of the expandable mandrel 705 substantially as described above with reference to Figs. 1-6. The tubular member 715 may be fabricated from any number of materials such as, for example, Oilfield Country Tubular Goods (OCTG), automotive grade steel or plastics. In a preferred embodiment, the tubular member 715 is fabricated from OCTG.

In a preferred embodiment, the tubular member 715 has a substantially annular cross-section. In a particularly preferred embodiment, the tubular member 715 has a substantially circular annular cross-section.

The tubular member 715 preferably includes an upper section 805, an intermediate section 810, and a lower section 815. The upper section 805 of the tubular member 715 preferably is defined by the region beginning in the vicinity of the mandrel container 710 and ending with the top section 820 of the tubular member 715. The intermediate section 810 of the tubular member 715 is preferably defined by the region beginning in the vicinity of the top of the mandrel container 710 and ending with the region in the vicinity of the mandrel 705. The lower section of the tubular member 715 is preferably defined by the region beginning in the vicinity of the mandrel 705 and ending at the bottom 825 of the tubular member 715.

In a preferred embodiment, the wall thickness of the upper section 805 of the tubular member 715 is greater than the wall thicknesses of the intermediate and lower sections 810 and 815 of the tubular member 715 in order to optimally facilitate the initiation of the extrusion process and optimally permit the apparatus 700 to be positioned in locations in the wellbore having tight clearances.

The outer diameter and wall thickness of the upper section 805 of the tubular member 715 may range, for example, from about 1.05 to 48 inches and 1/8 to 2 inches, respectively. In a preferred embodiment, the outer diameter and wall thickness of the upper section 805 of the tubular member 715 range from about 3.5 to 16 inches and 3/8 to 1.5 inches, respectively.

The outer diameter and wall thickness of the intermediate section 810 of the tubular member 715 may range, for example, from about 2.5 to 50 inches and 1/16 to 1.5 inches, respectively. In a preferred embodiment, the outer diameter and wall thickness of the intermediate section 810 of the tubular member 715 range from about 3.5 to 19 inches and 1/8 to 1.25 inches, respectively.

The outer diameter and wall thickness of the lower section 815 of the tubular member 715 may range, for example, from about 2.5 to 50 inches and 1/16 to 1.25 inches, respectively. In a preferred embodiment, the outer diameter and wall thickness of the lower section 810 of the tubular member 715 range from about 3.5 to 19 inches and 1/8 to 1.25 inches, respectively. In a

particularly preferred embodiment, the wall thickness of the lower section 815 of the tubular member 715 is further increased to increase the strength of the shoe 720 when drillable materials such as, for example, aluminum are used.

The tubular member 715 preferably comprises a solid tubular member.

5 In a preferred embodiment, the end portion 820 of the tubular member 715 is slotted, perforated, or otherwise modified to catch or slow down the mandrel 705 when it completes the extrusion of tubular member 715. In a preferred embodiment, the length of the tubular member 715 is limited to minimize the possibility of buckling. For typical tubular member 715 materials, the length of
10 the tubular member 715 is preferably limited to between about 40 to 20,000 feet in length.

The shoe 720 is coupled to the expandable mandrel 705 and the tubular member 715. The shoe 720 includes the fluid passage 740. In a preferred embodiment, the shoe 720 further includes an inlet passage 830, and one or
15 more jet ports 835. In a particularly preferred embodiment, the cross-sectional-shape of the inlet passage 830 is adapted to receive a latch-down dart, or other similar elements, for blocking the inlet passage 830. The interior of the shoe 720 preferably includes a body of solid material 840 for increasing the strength of the shoe 720. In a particularly preferred embodiment, the body of solid
20 material 840 comprises aluminum.

The shoe 720 may comprise any number of conventional commercially available shoes such as, for example, Super Seal II Down-Jet float shoe, or guide shoe with a sealing sleeve for a latch down plug modified in accordance with the teachings of the present disclosure. In a preferred embodiment, the shoe 720
25 comprises an aluminum down-jet guide shoe with a sealing sleeve for a latch-down plug available from Halliburton Energy Services in Dallas, TX, modified in accordance with the teachings of the present disclosure, in order to optimize guiding the tubular member 715 in the wellbore, optimize the seal between the tubular member 715 and an existing wellbore casing, and to optimally facilitate
30 the removal of the shoe 720 by drilling it out after completion of the extrusion process.

The lower cup seal 725 is coupled to and supported by the support member 745. The lower cup seal 725 prevents foreign materials from entering the interior region of the tubular member 715 above the expandable mandrel 705. The lower cup seal 725 may comprise any number of conventional
5 commercially available cup seals such as, for example, TP cups or Selective Injection Packer (SIP) cups modified in accordance with the teachings of the present disclosure. In a preferred embodiment, the lower cup seal 725 comprises a SIP cup, available from Halliburton Energy Services in Dallas, TX in order to optimally provide a debris barrier and hold a body of lubricant.

10 The upper cup seal 730 is coupled to and supported by the support member 760. The upper cup seal 730 prevents foreign materials from entering the interior region of the tubular member 715. The upper cup seal 730 may comprise any number of conventional commercially available cup seals such as, for example, TP cups or Selective Injection Packer (SIP) cup modified in
15 accordance with the teachings of the present disclosure. In a preferred embodiment, the upper cup seal 730 comprises a SIP cup available from Halliburton Energy Services in Dallas, TX in order to optimally provide a debris barrier and contain a body of lubricant.

The fluid passage 735 permits fluidic materials to be transported to and
20 from the interior region of the tubular member 715 below the expandable mandrel 705. The fluid passage 735 is fluidically coupled to the fluid passage 740. The fluid passage 735 is preferably coupled to and positioned within the support member 760, the support member 745, the mandrel container 710, and the expandable mandrel 705. The fluid passage 735 preferably extends from a
25 position adjacent to the surface to the bottom of the expandable mandrel 705. The fluid passage 735 is preferably positioned along a centerline of the apparatus 700. The fluid passage 735 is preferably selected to transport materials such as cement, drilling mud or epoxies at flow rates and pressures ranging from about 40 to 3,000 gallons/minute and 500 to 9,000 psi in order to
30 optimally provide sufficient operating pressures to extrude the tubular member 715 off of the expandable mandrel 705.

As described above with reference to Figs. 1-6, during placement of the apparatus 700 within a new section of a wellbore, fluidic materials forced up the fluid passage 735 can be released into the wellbore above the tubular member 715. In a preferred embodiment, the apparatus 700 further includes a pressure release passage that is coupled to and positioned within the support member 260. The pressure release passage is further fluidically coupled to the fluid passage 735. The pressure release passage preferably includes a control valve for controllably opening and closing the fluid passage. In a preferred embodiment, the control valve is pressure activated in order to controllably minimize surge pressures. The pressure release passage is preferably positioned substantially orthogonal to the centerline of the apparatus 700. The pressure release passage is preferably selected to convey materials such as cement, drilling mud or epoxies at flow rates and pressures ranging from about 0 to 500 gallons/minute and 0 to 1,000 psi in order to reduce the drag on the apparatus 700 during insertion into a new section of a wellbore and to minimize surge pressures on the new wellbore section.

The fluid passage 740 permits fluidic materials to be transported to and from the region exterior to the tubular member 715. The fluid passage 740 is preferably coupled to and positioned within the shoe 720 in fluidic communication with the interior region of the tubular member 715 below the expandable mandrel 705. The fluid passage 740 preferably has a cross-sectional shape that permits a plug, or other similar device, to be placed in the inlet 830 of the fluid passage 740 to thereby block further passage of fluidic materials. In this manner, the interior region of the tubular member 715 below the expandable mandrel 705 can be optimally fluidically isolated from the region exterior to the tubular member 715. This permits the interior region of the tubular member 715 below the expandable mandrel 205 to be pressurized.

The fluid passage 740 is preferably positioned substantially along the centerline of the apparatus 700. The fluid passage 740 is preferably selected to convey materials such as cement, drilling mud or epoxies at flow rates and pressures ranging from about 0 to 3,000 gallons/minute and 0 to 9,000 psi in order to optimally fill an annular region between the tubular member 715 and a

25791.8

new section of a wellbore with fluidic materials. In a preferred embodiment, the fluid passage 740 includes an inlet passage 830 having a geometry that can receive a dart and/or a ball sealing member. In this manner, the fluid passage 240 can be sealed off by introducing a plug, dart and/or ball sealing elements 5 into the fluid passage 230.

In a preferred embodiment, the apparatus 700 further includes one or more seals 845 coupled to and supported by the end portion 820 of the tubular member 715. The seals 845 are further positioned on an outer surface of the end portion 820 of the tubular member 715. The seals 845 permit the 10 overlapping joint between an end portion of preexisting casing and the end portion 820 of the tubular member 715 to be fluidically sealed. The seals 845 may comprise any number of conventional commercially available seals such as, for example, lead, rubber, Teflon, or epoxy seals modified in accordance with the teachings of the present disclosure. In a preferred embodiment, the seals 15 845 comprise seals molded from StrataLock epoxy available from Halliburton Energy Services in Dallas, TX in order to optimally provide a hydraulic seal and a load bearing interference fit in the overlapping joint between the tubular member 715 and an existing casing with optimal load bearing capacity to support the tubular member 715.

20 In a preferred embodiment, the seals 845 are selected to provide a sufficient frictional force to support the expanded tubular member 715 from the existing casing. In a preferred embodiment, the frictional force provided by the seals 845 ranges from about 1,000 to 1,000,000 lbf in order to optimally support the expanded tubular member 715.

25 The support member 745 is preferably coupled to the expandable mandrel 705 and the overshot connection 755. The support member 745 preferably comprises an annular member having sufficient strength to carry the apparatus 700 into a new section of a wellbore. The support member 745 may comprise any number of conventional commercially available support members 30 such as, for example, steel drill pipe, coiled tubing or other high strength tubular modified in accordance with the teachings of the present disclosure. In

a preferred embodiment, the support member 745 comprises conventional drill pipe available from various steel mills in the United States.

In a preferred embodiment, a body of lubricant 750 is provided in the annular region above the expandable mandrel container 710 within the interior
5 of the tubular member 715. In this manner, the extrusion of the tubular member 715 off of the expandable mandrel 705 is facilitated. The lubricant 705 may comprise any number of conventional commercially available lubricants such as, for example, Lubriplate, chlorine based lubricants, oil based lubricants, or Climax 1500 Antisieze (3100). In a preferred embodiment, the lubricant 750
10 comprises Climax 1500 Antisieze (3100) available from Halliburton Energy Services in Houston, TX in order to optimally provide lubrication to facilitate the extrusion process.

The overshot connection 755 is coupled to the support member 745 and the support member 760. The overshot connection 755 preferably permits the
15 support member 745 to be removably coupled to the support member 760. The overshot connection 755 may comprise any number of conventional commercially available overshot connections such as, for example, Innerstring Sealing Adapter, Innerstring Flat-Face Sealing Adapter or EZ Drill Setting Tool Stinger. In a preferred embodiment, the overshot connection 755 comprises a
20 Innerstring Adapter with an Upper Guide available from Halliburton Energy Services in Dallas, TX.

The support member 760 is preferably coupled to the overshot connection 755 and a surface support structure (not illustrated). The support member 760 preferably comprises an annular member having sufficient
25 strength to carry the apparatus 700 into a new section of a wellbore. The support member 760 may comprise any number of conventional commercially available support members such as, for example, steel drill pipe, coiled tubing or other high strength tubulars modified in accordance with the teachings of the present disclosure. In a preferred embodiment, the support member 760
30 comprises a conventional drill pipe available from steel mills in the United States.

The stabilizer 765 is preferably coupled to the support member 760. The stabilizer 765 also preferably stabilizes the components of the apparatus 700 within the tubular member 715. The stabilizer 765 preferably comprises a spherical member having an outside diameter that is about 80 to 99% of the interior diameter of the tubular member 715 in order to optimally minimize buckling of the tubular member 715. The stabilizer 765 may comprise any number of conventional commercially available stabilizers such as, for example, EZ Drill Star Guides, packer shoes or drag blocks modified in accordance with the teachings of the present disclosure. In a preferred embodiment, the stabilizer 765 comprises a sealing adapter upper guide available from Halliburton Energy Services in Dallas, TX.

In a preferred embodiment, the support members 745 and 760 are thoroughly cleaned prior to assembly to the remaining portions of the apparatus 700. In this manner, the introduction of foreign material into the apparatus 700 is minimized. This minimizes the possibility of foreign material clogging the various flow passages and valves of the apparatus 700.

In a preferred embodiment, before or after positioning the apparatus 700 within a new section of a wellbore, a couple of wellbore volumes are circulated through the various flow passages of the apparatus 700 in order to ensure that no foreign materials are located within the wellbore that might clog up the various flow passages and valves of the apparatus 700 and to ensure that no foreign material interferes with the expansion mandrel 705 during the expansion process.

In a preferred embodiment, the apparatus 700 is operated substantially as described above with reference to Figs. 1-7 to form a new section of casing within a wellbore.

As illustrated in Fig. 8, in an alternative preferred embodiment, the method and apparatus described herein is used to repair an existing wellbore casing 805 by forming a tubular liner 810 inside of the existing wellbore casing 805. In a preferred embodiment, an outer annular lining of cement is not provided in the repaired section. In the alternative preferred embodiment, any number of fluidic materials can be used to expand the tubular liner 810 into

intimate contact with the damaged section of the wellbore casing such as, for example, cement, epoxy, slag mix, or drilling mud. In the alternative preferred embodiment, sealing members 815 are preferably provided at both ends of the tubular member in order to optimally provide a fluidic seal. In an alternative
5 preferred embodiment, the tubular liner 810 is formed within a horizontally positioned pipeline section, such as those used to transport hydrocarbons or water, with the tubular liner 810 placed in an overlapping relationship with the adjacent pipeline section. In this manner, underground pipelines can be repaired without having to dig out and replace the damaged sections.

10 In another alternative preferred embodiment, the method and apparatus described herein is used to directly line a wellbore with a tubular liner 810. In a preferred embodiment, an outer annular lining of cement is not provided between the tubular liner 810 and the wellbore. In the alternative preferred embodiment, any number of fluidic materials can be used to expand the tubular
15 liner 810 into intimate contact with the wellbore such as, for example, cement, epoxy, slag mix, or drilling mud.

Referring now to Figs. 9, 9a, 9b and 9c, a preferred embodiment of an apparatus 900 for forming a wellbore casing includes an expandible tubular member 902, a support member 904, an expandible mandrel or pig 906, and a
20 shoe 908. In a preferred embodiment, the design and construction of the mandrel 906 and shoe 908 permits easy removal of those elements by drilling them out. In this manner, the assembly 900 can be easily removed from a wellbore using a conventional drilling apparatus and corresponding drilling methods.

25 The expandible tubular member 902 preferably includes an upper portion 910, an intermediate portion 912 and a lower portion 914. During operation of the apparatus 900, the tubular member 902 is preferably extruded off of the mandrel 906 by pressurizing an interior region 966 of the tubular member 902. The tubular member 902 preferably has a substantially annular
30 cross-section.

In a particularly preferred embodiment, an expandible tubular member 915 is coupled to the upper portion 910 of the expandible tubular member 902.

During operation of the apparatus 900, the tubular member 915 is preferably extruded off of the mandrel 906 by pressurizing the interior region 966 of the tubular member 902. The tubular member 915 preferably has a substantially annular cross-section. In a preferred embodiment, the wall thickness of the 5 tubular member 915 is greater than the wall thickness of the tubular member 902.

The tubular member 915 may be fabricated from any number of conventional commercially available materials such as, for example, oilfield tubulars, low alloy steels, titanium or stainless steels. In a preferred 10 embodiment, the tubular member 915 is fabricated from oilfield tubulars in order to optimally provide approximately the same mechanical properties as the tubular member 902. In a particularly preferred embodiment, the tubular member 915 has a plastic yield point ranging from about 40,000 to 135,000 psi in order to optimally provide approximately the same yield properties as the 15 tubular member 902. The tubular member 915 may comprise a plurality of tubular members coupled end to end.

In a preferred embodiment, the upper end portion of the tubular member 915 includes one or more sealing members for optimally providing a fluidic and/or gaseous seal with an existing section of wellbore casing.

20 In a preferred embodiment, the combined length of the tubular members 902 and 915 are limited to minimize the possibility of buckling. For typical tubular member materials, the combined length of the tubular members 902 and 915 are limited to between about 40 to 20,000 feet in length.

The lower portion 914 of the tubular member 902 is preferably coupled to 25 the shoe 908 by a threaded connection 968. The intermediate portion 912 of the tubular member 902 preferably is placed in intimate sliding contact with the mandrel 906.

The tubular member 902 may be fabricated from any number of conventional commercially available materials such as, for example, oilfield 30 tubulars, low alloy steels, titanium or stainless steels. In a preferred embodiment, the tubular member 902 is fabricated from oilfield tubulars in order to optimally provide approximately the same mechanical properties as the

tubular member 915. In a particularly preferred embodiment, the tubular member 902 has a plastic yield point ranging from about 40,000 to 135,000 psi in order to optimally provide approximately the same yield properties as the tubular member 915.

- 5 The wall thickness of the upper, intermediate, and lower portions, 910, 912 and 914 of the tubular member 902 may range, for example, from about 1/16 to 1.5 inches. In a preferred embodiment, the wall thickness of the upper, intermediate, and lower portions, 910, 912 and 914 of the tubular member 902 range from about 1/8 to 1.25 in order to optimally provide wall thickness that
- 10 are about the same as the tubular member 915. In a preferred embodiment, the wall thickness of the lower portion 914 is less than or equal to the wall thickness of the upper portion 910 in order to optimally provide a geometry that will fit into tight clearances downhole.

- The outer diameter of the upper, intermediate, and lower portions, 910,
- 15 912 and 914 of the tubular member 902 may range, for example, from about 1.05 to 48 inches. In a preferred embodiment, the outer diameter of the upper, intermediate, and lower portions, 910, 912 and 914 of the tubular member 902 range from about 3 1/2 to 19 inches in order to optimally provide the ability to expand the most commonly used oilfield tubulars.

- 20 The length of the tubular member 902 is preferably limited to between about 2 to 5 feet in order to optimally provide enough length to contain the mandrel 906 and a body of lubricant.

- The tubular member 902 may comprise any number of conventional commercially available tubular members modified in accordance with the
- 25 teachings of the present disclosure. In a preferred embodiment, the tubular member 902 comprises Oilfield Country Tubular Goods available from various U.S. steel mills. The tubular member 915 may comprise any number of conventional commercially available tubular members modified in accordance with the teachings of the present disclosure. In a preferred embodiment, the
- 30 tubular member 915 comprises Oilfield Country Tubular Goods available from various U.S. steel mills.

The various elements of the tubular member 902 may be coupled using any number of conventional process such as, for example, threaded connections, welding or machined from one piece. In a preferred embodiment, the various elements of the tubular member 902 are coupled using welding. The tubular member 902 may comprise a plurality of tubular elements that are coupled end to end. The various elements of the tubular member 915 may be coupled using any number of conventional process such as, for example, threaded connections, welding or machined from one piece. In a preferred embodiment, the various elements of the tubular member 915 are coupled using welding. The tubular member 915 may comprise a plurality of tubular elements that are coupled end to end. The tubular members 902 and 915 may be coupled using any number of conventional process such as, for example, threaded connections, welding or machined from one piece.

The support member 904 preferably includes an innerstring adapter 916, a fluid passage 918, an upper guide 920, and a coupling 922. During operation of the apparatus 900, the support member 904 preferably supports the apparatus 900 during movement of the apparatus 900 within a wellbore. The support member 904 preferably has a substantially annular cross-section.

The support member 904 may be fabricated from any number of conventional commercially available materials such as, for example, oilfield tubulars, low alloy steel, coiled tubing or stainless steel. In a preferred embodiment, the support member 904 is fabricated from low alloy steel in order to optimally provide high yield strength.

The innerstring adaptor 916 preferably is coupled to and supported by a conventional drill string support from a surface location. The innerstring adaptor 916 may be coupled to a conventional drill string support 971 by a threaded connection 970.

The fluid passage 918 is preferably used to convey fluids and other materials to and from the apparatus 900. In a preferred embodiment, the fluid passage 918 is fluidically coupled to the fluid passage 952. In a preferred embodiment, the fluid passage 918 is used to convey hardenable fluidic sealing materials to and from the apparatus 900. In a particularly preferred

embodiment, the fluid passage 918 may include one or more pressure relief passages (not illustrated) to release fluid pressure during positioning of the apparatus 900 within a wellbore. In a preferred embodiment, the fluid passage 918 is positioned along a longitudinal centerline of the apparatus 900. In a
5 preferred embodiment, the fluid passage 918 is selected to permit the conveyance of hardenable fluidic materials at operating pressures ranging from about 0 to 9,000 psi.

The upper guide 920 is coupled to an upper portion of the support member 904. The upper guide 920 preferably is adapted to center the support
10 member 904 within the tubular member 915. The upper guide 920 may comprise any number of conventional guide members modified in accordance with the teachings of the present disclosure. In a preferred embodiment, the upper guide 920 comprises an innerstring adapter available from Halliburton Energy Services in Dallas, TX order to optimally guide the apparatus 900
15 within the tubular member 915.

The coupling 922 couples the support member 904 to the mandrel 906. The coupling 922 preferably comprises a conventional threaded connection.

The various elements of the support member 904 may be coupled using any number of conventional processes such as, for example, welding, threaded
20 connections or machined from one piece. In a preferred embodiment, the various elements of the support member 904 are coupled using threaded connections.

The mandrel 906 preferably includes a retainer 924, a rubber cup 926, an expansion cone 928, a lower cone retainer 930, a body of cement 932, a lower
25 guide 934, an extension sleeve 936, a spacer 938, a housing 940, a sealing sleeve 942, an upper cone retainer 944, a lubricator mandrel 946, a lubricator sleeve 948, a guide 950, and a fluid passage 952.

The retainer 924 is coupled to the lubricator mandrel 946, lubricator sleeve 948, and the rubber cup 926. The retainer 924 couples the rubber cup
30 926 to the lubricator sleeve 948. The retainer 924 preferably has a substantially annular cross-section. The retainer 924 may comprise any number of

conventional commercially available retainers such as, for example, slotted spring pins or roll pin.

The rubber cup 926 is coupled to the retainer 924, the lubricator mandrel 946, and the lubricator sleeve 948. The rubber cup 926 prevents the entry of
5 foreign materials into the interior region 972 of the tubular member 902 below the rubber cup 926. The rubber cup 926 may comprise any number of conventional commercially available rubber cups such as, for example, TP cups or Selective Injection Packer (SIP) cup. In a preferred embodiment, the rubber cup 926 comprises a SIP cup available from Halliburton Energy Services in
10 Dallas, TX in order to optimally block foreign materials.

In a particularly preferred embodiment, a body of lubricant is further provided in the interior region 972 of the tubular member 902 in order to lubricate the interface between the exterior surface of the mandrel 902 and the interior surface of the tubular members 902 and 915. The lubricant may
15 comprise any number of conventional commercially available lubricants such as, for example, Lubriplate, chlorine based lubricants, oil based lubricants or Climax 1500 Antiseize (3100). In a preferred embodiment, the lubricant comprises Climax 1500 Antiseize (3100) available from Climax Lubricants and Equipment Co. in Houston, TX in order to optimally provide lubrication to
20 facilitate the extrusion process.

The expansion cone 928 is coupled to the lower cone retainer 930, the body of cement 932, the lower guide 934, the extension sleeve 936, the housing 940, and the upper cone retainer 944. In a preferred embodiment, during operation of the apparatus 900, the tubular members 902 and 915 are extruded
25 off of the outer surface of the expansion cone 928. In a preferred embodiment, axial movement of the expansion cone 928 is prevented by the lower cone retainer 930, housing 940 and the upper cone retainer 944. Inner radial movement of the expansion cone 928 is prevented by the body of cement 932, the housing 940, and the upper cone retainer 944.

30 The expansion cone 928 preferably has a substantially annular cross section. The outside diameter of the expansion cone 928 is preferably tapered to provide a cone shape. The wall thickness of the expansion cone 928 may

range, for example, from about 0.125 to 3 inches. In a preferred embodiment, the wall thickness of the expansion cone 928 ranges from about 0.25 to 0.75 inches in order to optimally provide adequate compressive strength with minimal material. The maximum and minimum outside diameters of the expansion cone 928 may range, for example, from about 1 to 47 inches. In a preferred embodiment, the maximum and minimum outside diameters of the expansion cone 928 range from about 3.5 to 19 in order to optimally provide expansion of generally available oilfield tubulars

The expansion cone 928 may be fabricated from any number of conventional commercially available materials such as, for example, ceramic, tool steel, titanium or low alloy steel. In a preferred embodiment, the expansion cone 928 is fabricated from tool steel in order to optimally provide high strength and abrasion resistance. The surface hardness of the outer surface of the expansion cone 928 may range, for example, from about 50 Rockwell C to 70 Rockwell C. In a preferred embodiment, the surface hardness of the outer surface of the expansion cone 928 ranges from about 58 Rockwell C to 62 Rockwell C in order to optimally provide high yield strength. In a preferred embodiment, the expansion cone 928 is heat treated to optimally provide a hard outer surface and a resilient interior body in order to optimally provide abrasion resistance and fracture toughness.

The lower cone retainer 930 is coupled to the expansion cone 928 and the housing 940. In a preferred embodiment, axial movement of the expansion cone 928 is prevented by the lower cone retainer 930. Preferably, the lower cone retainer 930 has a substantially annular cross-section.

The lower cone retainer 930 may be fabricated from any number of conventional commercially available materials such as, for example, ceramic, tool steel, titanium or low alloy steel. In a preferred embodiment, the lower cone retainer 930 is fabricated from tool steel in order to optimally provide high strength and abrasion resistance. The surface hardness of the outer surface of the lower cone retainer 930 may range, for example, from about 50 Rockwell C to 70 Rockwell C. In a preferred embodiment, the surface hardness of the outer surface of the lower cone retainer 930 ranges from about 58 Rockwell C to 62

Rockwell C in order to optimally provide high yield strength. In a preferred embodiment, the lower cone retainer 930 is heat treated to optimally provide a hard outer surface and a resilient interior body in order to optimally provide abrasion resistance and fracture toughness.

- 5 In a preferred embodiment, the lower cone retainer 930 and the expansion cone 928 are formed as an integral one-piece element in order reduce the number of components and increase the overall strength of the apparatus. The outer surface of the lower cone retainer 930 preferably mates with the inner surfaces of the tubular members 902 and 915.
- 10 The body of cement 932 is positioned within the interior of the mandrel 906. The body of cement 932 provides an inner bearing structure for the mandrel 906. The body of cement 932 further may be easily drilled out using a conventional drill device. In this manner, the mandrel 906 may be easily removed using a conventional drilling device.
- 15 The body of cement 932 may comprise any number of conventional commercially available cement compounds. Alternatively, aluminum, cast iron or some other drillable metallic, composite, or aggregate material may be substituted for cement. The body of cement 932 preferably has a substantially annular cross-section.
- 20 The lower guide 934 is coupled to the extension sleeve 936 and housing 940. During operation of the apparatus 900, the lower guide 934 preferably helps guide the movement of the mandrel 906 within the tubular member 902. The lower guide 934 preferably has a substantially annular cross-section.
- The lower guide 934 may be fabricated from any number of conventional
- 25 commercially available materials such as, for example, oilfield tubulars, low alloy steel or stainless steel. In a preferred embodiment, the lower guide 934 is fabricated from low alloy steel in order to optimally provide high yield strength. The outer surface of the lower guide 934 preferably mates with the inner surface of the tubular member 902 to provide a sliding fit.
- 30 The extension sleeve 936 is coupled to the lower guide 934 and the housing 940. During operation of the apparatus 900, the extension sleeve 936 preferably helps guide the movement of the mandrel 906 within the tubular

member 902. The extension sleeve 936 preferably has a substantially annular cross-section.

The extension sleeve 936 may be fabricated from any number of conventional commercially available materials such as, for example, oilfield 5 tubulars, low alloy steel or stainless steel. In a preferred embodiment, the extension sleeve 936 is fabricated from low alloy steel in order to optimally provide high yield strength. The outer surface of the extension sleeve 936 preferably mates with the inner surface of the tubular member 902 to provide a sliding fit. In a preferred embodiment, the extension sleeve 936 and the lower 10 guide 934 are formed as an integral one-piece element in order to minimize the number of components and increase the strength of the apparatus.

The spacer 938 is coupled to the sealing sleeve 942. The spacer 938 preferably includes the fluid passage 952 and is adapted to mate with the extension tube 960 of the shoe 908. In this manner, a plug or dart can be 15 conveyed from the surface through the fluid passages 918 and 952 into the fluid passage 962. Preferably, the spacer 938 has a substantially annular cross-section.

The spacer 938 may be fabricated from any number of conventional commercially available materials such as, for example, steel, aluminum or cast 20 iron. In a preferred embodiment, the spacer 938 is fabricated from aluminum in order to optimally provide drillability. The end of the spacer 938 preferably mates with the end of the extension tube 960. In a preferred embodiment, the spacer 938 and the sealing sleeve 942 are formed as an integral one-piece element in order to reduce the number of components and increase the strength 25 of the apparatus.

The housing 940 is coupled to the lower guide 934, extension sleeve 936, expansion cone 928, body of cement 932, and lower cone retainer 930. During operation of the apparatus 900, the housing 940 preferably prevents inner radial motion of the expansion cone 928. Preferably, the housing 940 has a 30 substantially annular cross-section.

The housing 940 may be fabricated from any number of conventional commercially available materials such as, for example, oilfield tubulars, low

25791.8

alloy steel or stainless steel. In a preferred embodiment, the housing 940 is fabricated from low alloy steel in order to optimally provide high yield strength. In a preferred embodiment, the lower guide 934, extension sleeve 936 and housing 940 are formed as an integral one-piece element in order to minimize
5 the number of components and increase the strength of the apparatus.

In a particularly preferred embodiment, the interior surface of the housing 940 includes one or more protrusions to facilitate the connection between the housing 940 and the body of cement 932.

The sealing sleeve 942 is coupled to the support member 904, the body of
10 cement 932, the spacer 938, and the upper cone retainer 944. During operation of the apparatus, the sealing sleeve 942 preferably provides support for the mandrel 906. The sealing sleeve 942 is preferably coupled to the support member 904 using the coupling 922. Preferably, the sealing sleeve 942 has a substantially annular cross-section.

15 The sealing sleeve 942 may be fabricated from any number of conventional commercially available materials such as, for example, steel, aluminum or cast iron. In a preferred embodiment, the sealing sleeve 942 is fabricated from aluminum in order to optimally provide drillability of the sealing sleeve 942.

20 In a particularly preferred embodiment, the outer surface of the sealing sleeve 942 includes one or more protrusions to facilitate the connection between the sealing sleeve 942 and the body of cement 932.

In a particularly preferred embodiment, the spacer 938 and the sealing sleeve 942 are integrally formed as a one-piece element in order to minimize the
25 number of components.

The upper cone retainer 944 is coupled to the expansion cone 928, the sealing sleeve 942, and the body of cement 932. During operation of the apparatus 900, the upper cone retainer 944 preferably prevents axial motion of the expansion cone 928. Preferably, the upper cone retainer 944 has a
30 substantially annular cross-section.

The upper cone retainer 944 may be fabricated from any number of conventional commercially available materials such as, for example, steel,

aluminum or cast iron. In a preferred embodiment, the upper cone retainer 944 is fabricated from aluminum in order to optimally provide drillability of the upper cone retainer 944.

In a particularly preferred embodiment, the upper cone retainer 944 has a cross-sectional shape designed to provide increased rigidity. In a particularly preferred embodiment, the upper cone retainer 944 has a cross-sectional shape that is substantially I-shaped to provide increased rigidity and minimize the amount of material that would have to be drilled out.

The lubricator mandrel 946 is coupled to the retainer 924, the rubber cup 926, the upper cone retainer 944, the lubricator sleeve 948, and the guide 950. During operation of the apparatus 900, the lubricator mandrel 946 preferably contains the body of lubricant in the annular region 972 for lubricating the interface between the mandrel 906 and the tubular member 902. Preferably, the lubricator mandrel 946 has a substantially annular cross-section.

The lubricator mandrel 946 may be fabricated from any number of conventional commercially available materials such as, for example, steel, aluminum or cast iron. In a preferred embodiment, the lubricator mandrel 946 is fabricated from aluminum in order to optimally provide drillability of the lubricator mandrel 946.

The lubricator sleeve 948 is coupled to the lubricator mandrel 946, the retainer 924, the rubber cup 926, the upper cone retainer 944, the lubricator sleeve 948, and the guide 950. During operation of the apparatus 900, the lubricator sleeve 948 preferably supports the rubber cup 926. Preferably, the lubricator sleeve 948 has a substantially annular cross-section.

The lubricator sleeve 948 may be fabricated from any number of conventional commercially available materials such as, for example, steel, aluminum or cast iron. In a preferred embodiment, the lubricator sleeve 948 is fabricated from aluminum in order to optimally provide drillability of the lubricator sleeve 948.

As illustrated in Fig. 9c, the lubricator sleeve 948 is supported by the lubricator mandrel 946. The lubricator sleeve 948 in turn supports the rubber cup 926. The retainer 924 couples the rubber cup 926 to the lubricator sleeve

948. In a preferred embodiment, seals 949a and 949b are provided between the lubricator mandrel 946, lubricator sleeve 948, and rubber cup 926 in order to optimally seal off the interior region 972 of the tubular member 902.

The guide 950 is coupled to the lubricator mandrel 946, the retainer 924, 5 and the lubricator sleeve 948. During operation of the apparatus 900, the guide 950 preferably guides the apparatus on the support member 904. Preferably, the guide 950 has a substantially annular cross-section.

The guide 950 may be fabricated from any number of conventional commercially available materials such as, for example, steel, aluminum or cast 10 iron. In a preferred embodiment, the guide 950 is fabricated from aluminum order to optimally provide drillability of the guide 950.

The fluid passage 952 is coupled to the mandrel 906. During operation of the apparatus, the fluid passage 952 preferably conveys hardenable fluidic materials. In a preferred embodiment, the fluid passage 952 is positioned about 15 the centerline of the apparatus 900. In a particularly preferred embodiment, the fluid passage 952 is adapted to convey hardenable fluidic materials at pressures and flow rate ranging from about 0 to 9,000 psi and 0 to 3,000 gallons/min in order to optimally provide pressures and flow rates to displace and circulate fluids during the installation of the apparatus 900.

20 The various elements of the mandrel 906 may be coupled using any number of conventional process such as, for example, threaded connections, welded connections or cementing. In a preferred embodiment, the various elements of the mandrel 906 are coupled using threaded connections and cementing.

25 The shoe 908 preferably includes a housing 954, a body of cement 956, a sealing sleeve 958, an extension tube 960, a fluid passage 962, and one or more outlet jets 964.

The housing 954 is coupled to the body of cement 956 and the lower portion 914 of the tubular member 902. During operation of the apparatus 900, 30 the housing 954 preferably couples the lower portion of the tubular member 902 to the shoe 908 to facilitate the extrusion and positioning of the tubular

member 902. Preferably, the housing 954 has a substantially annular cross-section.

The housing 954 may be fabricated from any number of conventional commercially available materials such as, for example, steel or aluminum. In a preferred embodiment, the housing 954 is fabricated from aluminum in order to
5. optimally provide drillability of the housing 954.

In a particularly preferred embodiment, the interior surface of the housing 954 includes one or more protrusions to facilitate the connection between the body of cement 956 and the housing 954.

The body of cement 956 is coupled to the housing 954, and the sealing
10 sleeve 958. In a preferred embodiment, the composition of the body of cement 956 is selected to permit the body of cement to be easily drilled out using conventional drilling machines and processes.

The composition of the body of cement 956 may include any number of conventional cement compositions. In an alternative embodiment, a drillable
15 material such as, for example, aluminum or iron may be substituted for the body of cement 956.

The sealing sleeve 958 is coupled to the body of cement 956, the extension tube 960, the fluid passage 962, and one or more outlet jets 964. During operation of the apparatus 900, the sealing sleeve 958 preferably is
20 adapted to convey a hardenable fluidic material from the fluid passage 952 into the fluid passage 962 and then into the outlet jets 964 in order to inject the hardenable fluidic material into an annular region external to the tubular member 902. In a preferred embodiment, during operation of the apparatus 900, the sealing sleeve 958 further includes an inlet geometry that permits a
25 conventional plug or dart 974 to become lodged in the inlet of the sealing sleeve 958. In this manner, the fluid passage 962 may be blocked thereby fluidically isolating the interior region 966 of the tubular member 902.

In a preferred embodiment, the sealing sleeve 958 has a substantially annular cross-section. The sealing sleeve 958 may be fabricated from any
30 number of conventional commercially available materials such as, for example, steel, aluminum or cast iron. In a preferred embodiment, the sealing sleeve 958

is fabricated from aluminum in order to optimally provide drillability of the sealing sleeve 958.

The extension tube 960 is coupled to the sealing sleeve 958, the fluid passage 962, and one or more outlet jets 964. During operation of the apparatus 900, the extension tube 960 preferably is adapted to convey a hardenable fluidic material from the fluid passage 952 into the fluid passage 962 and then into the outlet jets 964 in order to inject the hardenable fluidic material into an annular region external to the tubular member 902. In a preferred embodiment, during operation of the apparatus 900, the sealing sleeve 960 further includes an inlet geometry that permits a conventional plug or dart 974 to become lodged in the inlet of the sealing sleeve 958. In this manner, the fluid passage 962 is blocked thereby fluidically isolating the interior region 966 of the tubular member 902. In a preferred embodiment, one end of the extension tube 960 mates with one end of the spacer 938 in order to optimally facilitate the transfer of material between the two.

In a preferred embodiment, the extension tube 960 has a substantially annular cross-section. The extension tube 960 may be fabricated from any number of conventional commercially available materials such as, for example, steel, aluminum or cast iron. In a preferred embodiment, the extension tube 960 is fabricated from aluminum in order to optimally provide drillability of the extension tube 960.

The fluid passage 962 is coupled to the sealing sleeve 958, the extension tube 960, and one or more outlet jets 964. During operation of the apparatus 900, the fluid passage 962 is preferably conveys hardenable fluidic materials. In a preferred embodiment, the fluid passage 962 is positioned about the centerline of the apparatus 900. In a particularly preferred embodiment, the fluid passage 962 is adapted to convey hardenable fluidic materials at pressures and flow rate ranging from about 0 to 9,000 psi and 0 to 3,000 gallons/min in order to optimally provide fluids at operationally efficient rates.

The outlet jets 964 are coupled to the sealing sleeve 958, the extension tube 960, and the fluid passage 962. During operation of the apparatus 900, the outlet jets 964 preferably convey hardenable fluidic material from the fluid

passage 962 to the region exterior of the apparatus 900. In a preferred embodiment, the shoe 908 includes a plurality of outlet jets 964.

In a preferred embodiment, the outlet jets 964 comprise passages drilled in the housing 954 and the body of cement 956 in order to simplify the construction of the apparatus 900.

The various elements of the shoe 908 may be coupled using any number of conventional process such as, for example, threaded connections, cement or machined from one piece of material. In a preferred embodiment, the various elements of the shoe 908 are coupled using cement.

10 In a preferred embodiment, the assembly 900 is operated substantially as described above with reference to Figs. 1-8 to create a new section of casing in a wellbore or to repair a wellbore casing or pipeline.

In particular, in order to extend a wellbore into a subterranean formation, a drill string is used in a well known manner to drill out material from the subterranean formation to form a new section.

The apparatus 900 for forming a wellbore casing in a subterranean formation is then positioned in the new section of the wellbore. In a particularly preferred embodiment, the apparatus 900 includes the tubular member 915. In a preferred embodiment, a hardenable fluidic sealing hardenable fluidic sealing material is then pumped from a surface location into the fluid passage 918. The hardenable fluidic sealing material then passes from the fluid passage 918 into the interior region 966 of the tubular member 902 below the mandrel 906. The hardenable fluidic sealing material then passes from the interior region 966 into the fluid passage 962. The hardenable fluidic sealing material then exits the apparatus 900 via the outlet jets 964 and fills an annular region between the exterior of the tubular member 902 and the interior wall of the new section of the wellbore. Continued pumping of the hardenable fluidic sealing material causes the material to fill up at least a portion of the annular region.

20
25
30 The hardenable fluidic sealing material is preferably pumped into the annular region at pressures and flow rates ranging, for example, from about 0 to 5,000 psi and 0 to 1,500 gallons/min, respectively. In a preferred

embodiment, the hardenable fluidic sealing material is pumped into the annular region at pressures and flow rates that are designed for the specific wellbore section in order to optimize the displacement of the hardenable fluidic sealing material while not creating high enough circulating pressures such that
5 circulation might be lost and that could cause the wellbore to collapse. The optimum pressures and flow rates are preferably determined using conventional empirical methods.

The hardenable fluidic sealing material may comprise any number of conventional commercially available hardenable fluidic sealing materials such
10 as, for example, slag mix, cement or epoxy. In a preferred embodiment, the hardenable fluidic sealing material comprises blended cements designed specifically for the well section being lined available from Halliburton Energy Services in Dallas, TX in order to optimally provide support for the new tubular member while also maintaining optimal flow characteristics so as to minimize
15 operational difficulties during the displacement of the cement in the annular region. The optimum composition of the blended cements is preferably determined using conventional empirical methods.

The annular region preferably is filled with the hardenable fluidic sealing material in sufficient quantities to ensure that, upon radial expansion of the
20 tubular member 902, the annular region of the new section of the wellbore will be filled with hardenable material.

Once the annular region has been adequately filled with hardenable fluidic sealing material, a plug or dart 974, or other similar device, preferably is introduced into the fluid passage 962 thereby fluidically isolating the interior
25 region 966 of the tubular member 902 from the external annular region. In a preferred embodiment, a non hardenable fluidic material is then pumped into the interior region 966 causing the interior region 966 to pressurize. In a particularly preferred embodiment, the plug or dart 974, or other similar device, preferably is introduced into the fluid passage 962 by introducing the plug or
30 dart 974, or other similar device into the non hardenable fluidic material. In this manner, the amount of cured material within the interior of the tubular members 902 and 915 is minimized.

Once the interior region 966 becomes sufficiently pressurized, the tubular members 902 and 915 are extruded off of the mandrel 906. The mandrel 906 may be fixed or it may be expandible. During the extrusion process, the mandrel 906 is raised out of the expanded portions of the tubular members 902 and 915 using the support member 904. During this extrusion process, the shoe 908 is preferably substantially stationary.

The plug or dart 974 is preferably placed into the fluid passage 962 by introducing the plug or dart 974 into the fluid passage 918 at a surface location in a conventional manner. The plug or dart 974 may comprise any number of conventional commercially available devices for plugging a fluid passage such as, for example, Multiple Stage Cementer (MSC) latch-down plug, Omega latch-down plug or three-wiper latch down plug modified in accordance with the teachings of the present disclosure. In a preferred embodiment, the plug or dart 974 comprises a MSC latch-down plug available from Halliburton Energy Services in Dallas, TX.

After placement of the plug or dart 974 in the fluid passage 962, the non-hardenable fluidic material is preferably pumped into the interior region 966 at pressures and flow rates ranging from approximately 500 to 9,000 psi and 40 to 3,000 gallons/min in order to optimally extrude the tubular members 902 and 915 off of the mandrel 906.

For typical tubular members 902 and 915, the extrusion of the tubular members 902 and 915 off of the expandable mandrel will begin when the pressure of the interior region 966 reaches approximately 500 to 9,000 psi. In a preferred embodiment, the extrusion of the tubular members 902 and 915 off of the mandrel 906 begins when the pressure of the interior region 966 reaches approximately 1,200 to 8,500 psi with a flow rate of about 40 to 1250 gallons/minute.

During the extrusion process, the mandrel 906 may be raised out of the expanded portions of the tubular members 902 and 915 at rates ranging, for example, from about 0 to 5 ft/sec. In a preferred embodiment, during the extrusion process, the mandrel 906 is raised out of the expanded portions of the tubular members 902 and 915 at rates ranging from about 0 to 2 ft/sec in order

to optimally provide pulling speed fast enough to permit efficient operation and permit full expansion of the tubular members 902 and 915 prior to curing of the hardenable fluidic sealing material; but not so fast that timely adjustment of operating parameters during operation is prevented.

5 When the upper end portion of the tubular member 915 is extruded off of the mandrel 906, the outer surface of the upper end portion of the tubular member 915 will preferably contact the interior surface of the lower end portion of the existing casing to form an fluid tight overlapping joint. The contact pressure of the overlapping joint may range, for example, from approximately
10 50 to 20,000 psi. In a preferred embodiment, the contact pressure of the overlapping joint between the upper end of the tubular member 915 and the existing section of wellbore casing ranges from approximately 400 to 10,000 psi in order to optimally provide contact pressure to activate the sealing members and provide optimal resistance such that the tubular member 915 and existing
15 wellbore casing will carry typical tensile and compressive loads.

In a preferred embodiment, the operating pressure and flow rate of the non hardenable fluidic material will be controllably ramped down when the mandrel 906 reaches the upper end portion of the tubular member 915. In this manner, the sudden release of pressure caused by the complete extrusion of the
20 tubular member 915 off of the expandable mandrel 906 can be minimized. In a preferred embodiment, the operating pressure is reduced in a substantially linear fashion from 100% to about 10% during the end of the extrusion process beginning when the mandrel 906 has completed approximately all but about the last 5 feet of the extrusion process.

25 In an alternative preferred embodiment, the operating pressure and/or flow rate of the hardenable fluidic sealing material and/or the non hardenable fluidic material are controlled during all phases of the operation of the apparatus 900 to minimize shock.

Alternatively, or in combination, a shock absorber is provided in the
30 support member 904 in order to absorb the shock caused by the sudden release of pressure.

Alternatively, or in combination, a mandrel catching structure is provided above the support member 904 in order to catch or at least decelerate the mandrel 906.

Once the extrusion process is completed, the mandrel 906 is removed 5 from the wellbore. In a preferred embodiment, either before or after the removal of the mandrel 906, the integrity of the fluidic seal of the overlapping joint between the upper portion of the tubular member 915 and the lower portion of the existing casing is tested using conventional methods. If the fluidic seal of the overlapping joint between the upper portion of the tubular 10 member 915 and the lower portion of the existing casing is satisfactory, then the uncured portion of any of the hardenable fluidic sealing material within the expanded tubular member 915 is then removed in a conventional manner. The hardenable fluidic sealing material within the annular region between the expanded tubular member 915 and the existing casing and new section of 15 wellbore is then allowed to cure.

Preferably any remaining cured hardenable fluidic sealing material within the interior of the expanded tubular members 902 and 915 is then removed in a conventional manner using a conventional drill string. The resulting new section of casing preferably includes the expanded tubular 20 members 902 and 915 and an outer annular layer of cured hardenable fluidic sealing material. The bottom portion of the apparatus 900 comprising the shoe 908 may then be removed by drilling out the shoe 908 using conventional drilling methods.

In an alternative embodiment, during the extrusion process, it may be 25 necessary to remove the entire apparatus 900 from the interior of the wellbore due to a malfunction. In this circumstance, a conventional drill string is used to drill out the interior sections of the apparatus 900 in order to facilitate the removal of the remaining sections. In a preferred embodiment, the interior elements of the apparatus 900 are fabricated from materials such as, for 30 example, cement and aluminum, that permit a conventional drill string to be employed to drill out the interior components..

In particular, in a preferred embodiment, the composition of the interior sections of the mandrel 906 and shoe 908, including one or more of the body of cement 932, the spacer 938, the sealing sleeve 942, the upper cone retainer 944, the lubricator mandrel 946, the lubricator sleeve 948, the guide 950, the housing 954, the body of cement 956, the sealing sleeve 958, and the extension tube 960, are selected to permit at least some of these components to be drilled out using conventional drilling methods and apparatus. In this manner, in the event of a malfunction downhole, the apparatus 900 may be easily removed from the wellbore.

10 Referring now to Figs. 10a, 10b, 10c, 10d, 10e, 10f, and 10g a method and apparatus for creating a tie-back liner in a wellbore will now be described. As illustrated in Fig. 10a, a wellbore 1000 positioned in a subterranean formation 1002 includes a first casing 1004 and a second casing 1006.

The first casing 1004 preferably includes a tubular liner 1008 and a cement annulus 1010. The second casing 1006 preferably includes a tubular liner 1012 and a cement annulus 1014. In a preferred embodiment, the second casing 1006 is formed by expanding a tubular member substantially as described above with reference to Figs. 1-9c or below with reference to Figs. 11a-11f.

20 In a particularly preferred embodiment, an upper portion of the tubular liner 1012 overlaps with a lower portion of the tubular liner 1008. In a particularly preferred embodiment, an outer surface of the upper portion of the tubular liner 1012 includes one or more sealing members 1016 for providing a fluidic seal between the tubular liners 1008 and 1012.

25 Referring to Fig. 10b, in order to create a tie-back liner that extends from the overlap between the first and second casings, 1004 and 1006, an apparatus 1100 is preferably provided that includes an expandable mandrel or pig 1105, a tubular member 1110, a shoe 1115, one or more cup seals 1120, a fluid passage 1130, a fluid passage 1135, one or more fluid passages 1140, seals 1145, and a support member 1150.

The expandable mandrel or pig 1105 is coupled to and supported by the support member 1150. The expandable mandrel 1105 is preferably adapted to

controllably expand in a radial direction. The expandable mandrel 1105 may comprise any number of conventional commercially available expandable mandrels modified in accordance with the teachings of the present disclosure. In a preferred embodiment, the expandable mandrel 1105 comprises a hydraulic expansion tool substantially as disclosed in U.S. Pat. No. 5,348,095, the disclosure of which is incorporated herein by reference, modified in accordance with the teachings of the present disclosure.

The tubular member 1110 is coupled to and supported by the expandable mandrel 1105. The tubular member 1105 is expanded in the radial direction and extruded off of the expandable mandrel 1105. The tubular member 1110 may be fabricated from any number of materials such as, for example, Oilfield Country Tubular Goods, 13 chromium tubing or plastic piping. In a preferred embodiment, the tubular member 1110 is fabricated from Oilfield Country Tubular Goods.

The inner and outer diameters of the tubular member 1110 may range, for example, from approximately 0.75 to 47 inches and 1.05 to 48 inches, respectively. In a preferred embodiment, the inner and outer diameters of the tubular member 1110 range from about 3 to 15.5 inches and 3.5 to 16 inches, respectively in order to optimally provide coverage for typical oilfield casing sizes. The tubular member 1110 preferably comprises a solid member.

In a preferred embodiment, the upper end portion of the tubular member 1110 is slotted, perforated, or otherwise modified to catch or slow down the mandrel 1105 when it completes the extrusion of tubular member 1110. In a preferred embodiment, the length of the tubular member 1110 is limited to minimize the possibility of buckling. For typical tubular member 1110 materials, the length of the tubular member 1110 is preferably limited to between about 40 to 20,000 feet in length.

The shoe 1115 is coupled to the expandable mandrel 1105 and the tubular member 1110. The shoe 1115 includes the fluid passage 1135. The shoe 1115 may comprise any number of conventional commercially available shoes such as, for example, Super Seal II float shoe, Super Seal II Down-Jet float shoe or a guide shoe with a sealing sleeve for a latch down plug modified in

accordance with the teachings of the present disclosure. In a preferred embodiment, the shoe 1115 comprises an aluminum down-jet guide shoe with a sealing sleeve for a latch-down plug with side ports radiating off of the exit flow port available from Halliburton Energy Services in Dallas, TX, modified in
5 accordance with the teachings of the present disclosure, in order to optimally guide the tubular member 1100 to the overlap between the tubular member 1100 and the casing 1012, optimally fluidically isolate the interior of the tubular member 1100 after the latch down plug has seated, and optimally permit drilling out of the shoe 1115 after completion of the expansion and cementing
10 operations.

In a preferred embodiment, the shoe 1115 includes one or more side outlet ports 1140 in fluidic communication with the fluid passage 1135. In this manner, the shoe 1115 injects hardenable fluidic sealing material into the region outside the shoe 1115 and tubular member 1110. In a preferred
15 embodiment, the shoe 1115 includes one or more of the fluid passages 1140 each having an inlet geometry that can receive a dart and/or a ball sealing member. In this manner, the fluid passages 1140 can be sealed off by introducing a plug, dart and/or ball sealing elements into the fluid passage 1130.

The cup seal 1120 is coupled to and supported by the support member
20 1150. The cup seal 1120 prevents foreign materials from entering the interior region of the tubular member 1110 adjacent to the expandable mandrel 1105. The cup seal 1120 may comprise any number of conventional commercially available cup seals such as, for example, TP cups or Selective Injection Packer (SIP) cups modified in accordance with the teachings of the present disclosure.
25 In a preferred embodiment, the cup seal 1120 comprises a SIP cup, available from Halliburton Energy Services in Dallas, TX in order to optimally provide a barrier to debris and contain a body of lubricant.

The fluid passage 1130 permits fluidic materials to be transported to and from the interior region of the tubular member 1110 below the expandable
30 mandrel 1105. The fluid passage 1130 is coupled to and positioned within the support member 1150 and the expandable mandrel 1105. The fluid passage 1130 preferably extends from a position adjacent to the surface to the bottom of

the expandable mandrel 1105. The fluid passage 1130 is preferably positioned along a centerline of the apparatus 1100. The fluid passage 1130 is preferably selected to transport materials such as cement, drilling mud or epoxies at flow rates and pressures ranging from about 0 to 3,000 gallons/minute and 0 to 5 9,000 psi in order to optimally provide sufficient operating pressures to circulate fluids at operationally efficient rates.

The fluid passage 1135 permits fluidic materials to be transmitted from fluid passage 1130 to the interior of the tubular member 1110 below the mandrel 1105.

10 The fluid passages 1140 permits fluidic materials to be transported to and from the region exterior to the tubular member 1110 and shoe 1115. The fluid passages 1140 are coupled to and positioned within the shoe 1115 in fluidic communication with the interior region of the tubular member 1110 below the expandable mandrel 1105. The fluid passages 1140 preferably have a cross-
15 sectional shape that permits a plug, or other similar device, to be placed in the fluid passages 1140 to thereby block further passage of fluidic materials. In this manner, the interior region of the tubular member 1110 below the expandable mandrel 1105 can be fluidically isolated from the region exterior to the tubular member 1105. This permits the interior region of the tubular member 1110
20 below the expandable mandrel 1105 to be pressurized.

The fluid passages 1140 are preferably positioned along the periphery of the shoe 1115. The fluid passages 1140 are preferably selected to convey materials such as cement, drilling mud or epoxies at flow rates and pressures ranging from about 0 to 3,000 gallons/minute and 0 to 9,000 psi in order to
25 optimally fill the annular region between the tubular member 1110 and the tubular liner 1008 with fluidic materials. In a preferred embodiment, the fluid passages 1140 include an inlet geometry that can receive a dart and/or a ball sealing member. In this manner, the fluid passages 1140 can be sealed off by introducing a plug, dart and/or ball sealing elements into the fluid passage
30 1130. In a preferred embodiment, the apparatus 1100 includes a plurality of fluid passage 1140.

In an alternative embodiment, the base of the shoe 1115 includes a single inlet passage coupled to the fluid passages 1140 that is adapted to receive a plug, or other similar device, to permit the interior region of the tubular member 1110 to be fluidically isolated from the exterior of the tubular member
5 1110.

The seals 1145 are coupled to and supported by a lower end portion of the tubular member 1110. The seals 1145 are further positioned on an outer surface of the lower end portion of the tubular member 1110. The seals 1145 permit the overlapping joint between the upper end portion of the casing 1012
10 and the lower end portion of the tubular member 1110 to be fluidically sealed.

The seals 1145 may comprise any number of conventional commercially available seals such as, for example, lead, rubber, Teflon or epoxy seals modified in accordance with the teachings of the present disclosure. In a preferred embodiment, the seals 1145 comprise seals molded from Stratalock epoxy
15 available from Halliburton Energy Services in Dallas, TX in order to optimally provide a hydraulic seal in the overlapping joint and optimally provide load carrying capacity to withstand the range of typical tensile and compressive loads.

In a preferred embodiment, the seals 1145 are selected to optimally
20 provide a sufficient frictional force to support the expanded tubular member 1110 from the tubular liner 1008. In a preferred embodiment, the frictional force provided by the seals 1145 ranges from about 1,000 to 1,000,000 lbf in tension and compression in order to optimally support the expanded tubular member 1110.

25 The support member 1150 is coupled to the expandable mandrel 1105, tubular member 1110, shoe 1115, and seal 1120. The support member 1150 preferably comprises an annular member having sufficient strength to carry the apparatus 1100 into the wellbore 1000. In a preferred embodiment, the support member 1150 further includes one or more conventional centralizers (not
30 illustrated) to help stabilize the tubular member 1110.

In a preferred embodiment, a quantity of lubricant 1150 is provided in the annular region above the expandable mandrel 1105 within the interior of

the tubular member 1110. In this manner, the extrusion of the tubular member 1110 off of the expandable mandrel 1105 is facilitated. The lubricant 1150 may comprise any number of conventional commercially available lubricants such as, for example, Lubriplate, chlorine based lubricants or Climax 5 1500 Antiseize (3100). In a preferred embodiment, the lubricant 1150 comprises Climax 1500 Antiseize (3100) available from Climax Lubricants and Equipment Co. in Houston, TX in order to optimally provide lubrication for the extrusion process.

In a preferred embodiment, the support member 1150 is thoroughly 10 cleaned prior to assembly to the remaining portions of the apparatus 1100. In this manner, the introduction of foreign material into the apparatus 1100 is minimized. This minimizes the possibility of foreign material clogging the various flow passages and valves of the apparatus 1100 and to ensure that no foreign material interferes with the expansion mandrel 1105 during the 15 extrusion process.

In a particularly preferred embodiment, the apparatus 1100 includes a packer 1155 coupled to the bottom section of the shoe 1115 for fluidicly isolating the region of the wellbore 1000 below the apparatus 1100. In this manner, fluidic materials are prevented from entering the region of the 20 wellbore 1000 below the apparatus 1100. The packer 1155 may comprise any number of conventional commercially available packers such as, for example, EZ Drill Packer, EZ SV Packer or a drillable cement retainer. In a preferred embodiment, the packer 1155 comprises an EZ Drill Packer available from Halliburton Energy Services in Dallas, TX. In an alternative embodiment, a 25 high gel strength pill may be set below the tie-back in place of the packer 1155. In another alternative embodiment, the packer 1155 may be omitted.

In a preferred embodiment, before or after positioning the apparatus 1100 within the wellbore 1100, a couple of wellbore volumes are circulated in order to ensure that no foreign materials are located within the wellbore 1000 30 that might clog up the various flow passages and valves of the apparatus 1100 and to ensure that no foreign material interferes with the operation of the expansion mandrel 1105.

As illustrated in Fig. 10c, a hardenable fluidic sealing material 1160 is then pumped from a surface location into the fluid passage 1130. The material 1160 then passes from the fluid passage 1130 into the interior region of the tubular member 1110 below the expandable mandrel 1105. The material 1160 then passes from the interior region of the tubular member 1110 into the fluid passages 1140. The material 1160 then exits the apparatus 1100 and fills the annular region between the exterior of the tubular member 1110 and the interior wall of the tubular liner 1008. Continued pumping of the material 1160 causes the material 1160 to fill up at least a portion of the annular region.

10 The material 1160 may be pumped into the annular region at pressures and flow rates ranging, for example, from about 0 to 5,000 psi and 0 to 1,500 gallons/min, respectively. In a preferred embodiment, the material 1160 is pumped into the annular region at pressures and flow rates specifically designed for the casing sizes being run, the annular spaces being filled, the
15 pumping equipment available, and the properties of the fluid being pumped. The optimum flow rates and pressures are preferably calculated using conventional empirical methods.

The hardenable fluidic sealing material 1160 may comprise any number of conventional commercially available hardenable fluidic sealing materials such
20 as, for example, slag mix, cement or epoxy. In a preferred embodiment, the hardenable fluidic sealing material 1160 comprises blended cements specifically designed for well section being tied-back, available from Halliburton Energy Services in Dallas, TX in order to optimally provide proper support for the tubular member 1110 while maintaining optimum flow characteristics so as to
25 minimize operational difficulties during the displacement of cement in the annular region. The optimum blend of the blended cements are preferably determined using conventional empirical methods.

The annular region may be filled with the material 1160 in sufficient quantities to ensure that, upon radial expansion of the tubular member 1110,
30 the annular region will be filled with material 1160.

As illustrated in Fig. 10d, once the annular region has been adequately filled with material 1160, one or more plugs 1165, or other similar devices,

preferably are introduced into the fluid passages 1140 thereby fluidically isolating the interior region of the tubular member 1110 from the annular region external to the tubular member 1110. In a preferred embodiment, a non hardenable fluidic material 1161 is then pumped into the interior region of the tubular member 1110 below the mandrel 1105 causing the interior region to pressurize. In a particularly preferred embodiment, the one or more plugs 1165, or other similar devices, are introduced into the fluid passage 1140 with the introduction of the non hardenable fluidic material. In this manner, the amount of hardenable fluidic material within the interior of the tubular member 1110 is minimized.

As illustrated in Fig. 10e, once the interior region becomes sufficiently pressurized, the tubular member 1110 is extruded off of the expandable mandrel 1105. During the extrusion process, the expandable mandrel 1105 is raised out of the expanded portion of the tubular member 1110.

The plugs 1165 are preferably placed into the fluid passages 1140 by introducing the plugs 1165 into the fluid passage 1130 at a surface location in a conventional manner. The plugs 1165 may comprise any number of conventional commercially available devices from plugging a fluid passage such as, for example, brass balls, plugs, rubber balls, or darts modified in accordance with the teachings of the present disclosure.

In a preferred embodiment, the plugs 1165 comprise low density rubber balls. In an alternative embodiment, for a shoe 1105 having a common central inlet passage, the plugs 1165 comprise a single latch down dart.

After placement of the plugs 1165 in the fluid passages 1140, the non hardenable fluidic material 1161 is preferably pumped into the interior region of the tubular member 1110 below the mandrel 1105 at pressures and flow rates ranging from approximately 500 to 9,000 psi and 40 to 3,000 gallons/min. In a preferred embodiment, after placement of the plugs 1165 in the fluid passages 1140, the non hardenable fluidic material 1161 is preferably pumped into the interior region of the tubular member 1110 below the mandrel 1105 at pressures and flow rates ranging from approximately 1200 to 8500 psi and 40 to 1250 gallons/min in order to optimally provide extrusion of typical tubulars.

For typical tubular members 1110, the extrusion of the tubular member 1110 off of the expandable mandrel 1105 will begin when the pressure of the interior region of the tubular member 1110 below the mandrel 1105 reaches, for example, approximately 1200 to 8500 psi. In a preferred embodiment, the
5 extrusion of the tubular member 1110 off of the expandable mandrel 1105 begins when the pressure of the interior region of the tubular member 1110 below the mandrel 1105 reaches approximately 1200 to 8500 psi.

During the extrusion process, the expandable mandrel 1105 may be raised out of the expanded portion of the tubular member 1110 at rates ranging,
10 for example, from about 0 to 5 ft/sec. In a preferred embodiment, during the extrusion process, the expandable mandrel 1105 is raised out of the expanded portion of the tubular member 1110 at rates ranging from about 0 to 2 ft/sec in order to optimally provide permit adjustment of operational parameters, and optimally ensure that the extrusion process will be completed before the
15 material 1160 cures.

In a preferred embodiment, at least a portion 1180 of the tubular member 1110 has an internal diameter less than the outside diameter of the mandrel 1105. In this manner, when the mandrel 1105 expands the section 1180 of the tubular member 1110, at least a portion of the expanded section
20 1180 effects a seal with at least the wellbore casing 1012. In a particularly preferred embodiment, the seal is effected by compressing the seals 1016 between the expanded section 1180 and the wellbore casing 1012. In a preferred embodiment, the contact pressure of the joint between the expanded section 1180 of the tubular member 1110 and the casing 1012 ranges from
25 about 500 to 10,000 psi in order to optimally provide pressure to activate the sealing members 1145 and provide optimal resistance to ensure that the joint will withstand typical extremes of tensile and compressive loads.

In an alternative preferred embodiment, substantially all of the entire length of the tubular member 1110 has an internal diameter less than the
30 outside diameter of the mandrel 1105. In this manner, extrusion of the tubular member 1110 by the mandrel 1105 results in contact between substantially all of the expanded tubular member 1110 and the existing casing 1008. In a

preferred embodiment, the contact pressure of the joint between the expanded tubular member 1110 and the casings 1008 and 1012 ranges from about 500 to 10,000 psi in order to optimally provide pressure to activate the sealing members 1145 and provide optimal resistance to ensure that the joint will
5 withstand typical extremes of tensile and compressive loads.

In a preferred embodiment, the operating pressure and flow rate of the material 1161 is controllably ramped down when the expandable mandrel 1105 reaches the upper end portion of the tubular member 1110. In this manner, the sudden release of pressure caused by the complete extrusion of the tubular
10 member 1110 off of the expandable mandrel 1105 can be minimized. In a preferred embodiment, the operating pressure of the fluidic material 1161 is reduced in a substantially linear fashion from 100% to about 10% during the end of the extrusion process beginning when the mandrel 1105 has completed approximately all but about 5 feet of the extrusion process.

15 Alternatively, or in combination, a shock absorber is provided in the support member 1150 in order to absorb the shock caused by the sudden release of pressure.

Alternatively, or in combination, a mandrel catching structure is provided in the upper end portion of the tubular member 1110 in order to catch
20 or at least decelerate the mandrel 1105.

Referring to Fig. 10f, once the extrusion process is completed, the expandable mandrel 1105 is removed from the wellbore 1000. In a preferred embodiment, either before or after the removal of the expandable mandrel 1105, the integrity of the fluidic seal of the joint between the upper portion of
25 the tubular member 1110 and the upper portion of the tubular liner 1108 is tested using conventional methods. If the fluidic seal of the joint between the upper portion of the tubular member 1110 and the upper portion of the tubular liner 1008 is satisfactory, then the uncured portion of the material 1160 within the expanded tubular member 1110 is then removed in a conventional manner.
30 The material 1160 within the annular region between the tubular member 1110 and the tubular liner 1008 is then allowed to cure.

As illustrated in Fig. 10f, preferably any remaining cured material 1160 within the interior of the expanded tubular member 1110 is then removed in a conventional manner using a conventional drill string. The resulting tie-back liner of casing 1170 includes the expanded tubular member 1110 and an outer
5 annular layer 1175 of cured material 1160.

As illustrated in Fig. 10g, the remaining bottom portion of the apparatus 1100 comprising the shoe 1115 and packer 1155 is then preferably removed by drilling out the shoe 1115 and packer 1155 using conventional drilling methods.

In a particularly preferred embodiment, the apparatus 1100 incorporates
10 the apparatus 900.

Referring now to Figs. 11a-11f, an embodiment of an apparatus and method for hanging a tubular liner off of an existing wellbore casing will now be described. As illustrated in Fig. 11a, a wellbore 1200 is positioned in a subterranean formation 1205. The wellbore 1200 includes an existing cased
15 section 1210 having a tubular casing 1215 and an annular outer layer of cement 1220.

In order to extend the wellbore 1200 into the subterranean formation 1205, a drill string 1225 is used in a well known manner to drill out material from the subterranean formation 1205 to form a new section 1230.

20 As illustrated in Fig. 11b, an apparatus 1300 for forming a wellbore casing in a subterranean formation is then positioned in the new section 1230 of the wellbore 100. The apparatus 1300 preferably includes an expandable mandrel or pig 1305, a tubular member 1310, a shoe 1315, a fluid passage 1320, a fluid passage 1330, a fluid passage 1335, seals 1340, a support member 1345,
25 and a wiper plug 1350.

The expandable mandrel 1305 is coupled to and supported by the support member 1345. The expandable mandrel 1305 is preferably adapted to controllably expand in a radial direction. The expandable mandrel 1305 may comprise any number of conventional commercially available expandable
30 mandrels modified in accordance with the teachings of the present disclosure. In a preferred embodiment, the expandable mandrel 1305 comprises a hydraulic expansion tool substantially as disclosed in U.S. Pat. No. 5,348,095, the

disclosure of which is incorporated herein by reference, modified in accordance with the teachings of the present disclosure.

The tubular member 1310 is coupled to and supported by the expandable mandrel 1305. The tubular member 1310 is preferably expanded in the radial direction and extruded off of the expandable mandrel 1305. The tubular member 1310 may be fabricated from any number of materials such as, for example, Oilfield Country Tubular Goods (OCTG), 13 chromium steel tubing/casing or plastic casing. In a preferred embodiment, the tubular member 1310 is fabricated from OCTG. The inner and outer diameters of the tubular member 1310 may range, for example, from approximately 0.75 to 47 inches and 1.05 to 48 inches, respectively. In a preferred embodiment, the inner and outer diameters of the tubular member 1310 range from about 3 to 15.5 inches and 3.5 to 16 inches, respectively in order to optimally provide minimal telescoping effect in the most commonly encountered wellbore sizes.

In a preferred embodiment, the tubular member 1310 includes an upper portion 1355, an intermediate portion 1360, and a lower portion 1365. In a preferred embodiment, the wall thickness and outer diameter of the upper portion 1355 of the tubular member 1310 range from about 3/8 to 1 1/2 inches and 3 1/2 to 16 inches, respectively. In a preferred embodiment, the wall thickness and outer diameter of the intermediate portion 1360 of the tubular member 1310 range from about 0.625 to 0.75 inches and 3 to 19 inches, respectively. In a preferred embodiment, the wall thickness and outer diameter of the lower portion 1365 of the tubular member 1310 range from about 3/8 to 1.5 inches and 3.5 to 16 inches, respectively.

In a particularly preferred embodiment, the outer diameter of the lower portion 1365 of the tubular member 1310 is significantly less than the outer diameters of the upper and intermediate portions, 1355 and 1360, of the tubular member 1310 in order to optimize the formation of a concentric and overlapping arrangement of wellbore casings. In this manner, as will be described below with reference to Figs. 12 and 13, a wellhead system is optimally provided. In a preferred embodiment, the formation of a wellhead system does not include the use of a hardenable fluidic material.

In a particularly preferred embodiment, the wall thickness of the intermediate section 1360 of the tubular member 1310 is less than or equal to the wall thickness of the upper and lower sections, 1355 and 1365, of the tubular member 1310 in order to optimally facilitate the initiation of the
5 extrusion process and optimally permit the placement of the apparatus in areas of the wellbore having tight clearances.

The tubular member 1310 preferably comprises a solid member. In a preferred embodiment, the upper end portion 1355 of the tubular member 1310 is slotted, perforated, or otherwise modified to catch or slow down the mandrel
10 1305 when it completes the extrusion of tubular member 1310. In a preferred embodiment, the length of the tubular member 1310 is limited to minimize the possibility of buckling. For typical tubular member 1310 materials, the length of the tubular member 1310 is preferably limited to between about 40 to 20,000 feet in length.

15 The shoe 1315 is coupled to the tubular member 1310. The shoe 1315 preferably includes fluid passages 1330 and 1335. The shoe 1315 may comprise any number of conventional commercially available shoes such as, for example, Super Seal II float shoe, Super Seal II Down-Jet float shoe or guide shoe with a sealing sleeve for a latch-down plug modified in accordance with the teachings
20 of the present disclosure. In a preferred embodiment, the shoe 1315 comprises an aluminum down-jet guide shoe with a sealing sleeve for a latch-down plug available from Halliburton Energy Services in Dallas, TX, modified in accordance with the teachings of the present disclosure, in order to optimally guide the tubular member 1310 into the wellbore 1200, optimally fluidically
25 isolate the interior of the tubular member 1310, and optimally permit the complete drill out of the shoe 1315 upon the completion of the extrusion and cementing operations.

In a preferred embodiment, the shoe 1315 further includes one or more side outlet ports in fluidic communication with the fluid passage 1330. In this
30 manner, the shoe 1315 preferably injects hardenable fluidic sealing material into the region outside the shoe 1315 and tubular member 1310. In a preferred embodiment, the shoe 1315 includes the fluid passage 1330 having an inlet

geometry that can receive a fluidic sealing member. In this manner, the fluid passage 1330 can be sealed off by introducing a plug, dart and/or ball sealing elements into the fluid passage 1330.

The fluid passage 1320 permits fluidic materials to be transported to and
5 from the interior region of the tubular member 1310 below the expandable mandrel 1305. The fluid passage 1320 is coupled to and positioned within the support member 1345 and the expandable mandrel 1305. The fluid passage 1320 preferably extends from a position adjacent to the surface to the bottom of the expandable mandrel 1305. The fluid passage 1320 is preferably positioned
10 along a centerline of the apparatus 1300. The fluid passage 1320 is preferably selected to transport materials such as cement, drilling mud, or epoxies at flow rates and pressures ranging from about 0 to 3,000 gallons/minute and 0 to 9,000 psi in order to optimally provide sufficient operating pressures to circulate fluids at operationally efficient rates.

15 The fluid passage 1330 permits fluidic materials to be transported to and from the region exterior to the tubular member 1310 and shoe 1315. The fluid passage 1330 is coupled to and positioned within the shoe 1315 in fluidic communication with the interior region 1370 of the tubular member 1310 below the expandable mandrel 1305. The fluid passage 1330 preferably has a cross-
20 sectional shape that permits a plug, or other similar device, to be placed in fluid passage 1330 to thereby block further passage of fluidic materials. In this manner, the interior region 1370 of the tubular member 1310 below the expandable mandrel 1305 can be fluidically isolated from the region exterior to the tubular member 1310. This permits the interior region 1370 of the tubular
25 member 1310 below the expandable mandrel 1305 to be pressurized. The fluid passage 1330 is preferably positioned substantially along the centerline of the apparatus 1300.

The fluid passage 1330 is preferably selected to convey materials such as cement, drilling mud or epoxies at flow rates and pressures ranging from about
30 0 to 3,000 gallons/minute and 0 to 9,000 psi in order to optimally fill the annular region between the tubular member 1310 and the new section 1230 of the wellbore 1200 with fluidic materials. In a preferred embodiment, the fluid

passage 1330 includes an inlet geometry that can receive a dart and/or a ball sealing member. In this manner, the fluid passage 1330 can be sealed off by introducing a plug, dart and/or ball sealing elements into the fluid passage 1320.

- 5 The fluid passage 1335 permits fluidic materials to be transported to and from the region exterior to the tubular member 1310 and shoe 1315. The fluid passage 1335 is coupled to and positioned within the shoe 1315 in fluidic communication with the fluid passage 1330. The fluid passage 1335 is preferably positioned substantially along the centerline of the apparatus 1300.
- 10 The fluid passage 1335 is preferably selected to convey materials such as cement, drilling mud or epoxies at flow rates and pressures ranging from about 0 to 3,000 gallons/minute and 0 to 9,000 psi in order to optimally fill the annular region between the tubular member 1310 and the new section 1230 of the wellbore 1200 with fluidic materials.
- 15 The seals 1340 are coupled to and supported by the upper end portion 1355 of the tubular member 1310. The seals 1340 are further positioned on an outer surface of the upper end portion 1355 of the tubular member 1310. The seals 1340 permit the overlapping joint between the lower end portion of the casing 1215 and the upper portion 1355 of the tubular member 1310 to be
- 20 fluidicly sealed. The seals 1340 may comprise any number of conventional commercially available seals such as, for example, lead, rubber, Teflon, or epoxy seals modified in accordance with the teachings of the present disclosure. In a preferred embodiment, the seals 1340 comprise seals molded from Stratalock epoxy available from Halliburton Energy Services in Dallas, TX in order to
- 25 optimally provide a hydraulic seal in the annulus of the overlapping joint while also creating optimal load bearing capability to withstand typical tensile and compressive loads.

In a preferred embodiment, the seals 1340 are selected to optimally provide a sufficient frictional force to support the expanded tubular member

30 1310 from the existing casing 1215. In a preferred embodiment, the frictional force provided by the seals 1340 ranges from about 1,000 to 1,000,000 lbf in order to optimally support the expanded tubular member 1310.

The support member 1345 is coupled to the expandable mandrel 1305, tubular member 1310, shoe 1315, and seals 1340. The support member 1345 preferably comprises an annular member having sufficient strength to carry the apparatus 1300 into the new section 1230 of the wellbore 1200. In a preferred 5 embodiment, the support member 1345 further includes one or more conventional centralizers (not illustrated) to help stabilize the tubular member 1310.

In a preferred embodiment, the support member 1345 is thoroughly cleaned prior to assembly to the remaining portions of the apparatus 1300. In 10 this manner, the introduction of foreign material into the apparatus 1300 is minimized. This minimizes the possibility of foreign material clogging the various flow passages and valves of the apparatus 1300 and to ensure that no foreign material interferes with the expansion process.

The wiper plug 1350 is coupled to the mandrel 1305 within the interior 15 region 1370 of the tubular member 1310. The wiper plug 1350 includes a fluid passage 1375 that is coupled to the fluid passage 1320. The wiper plug 1350 may comprise one or more conventional commercially available wiper plugs such as, for example, Multiple Stage Cementer latch-down plugs, Omega latch-down plugs or three-wiper latch-down plug modified in accordance with the 20 teachings of the present disclosure. In a preferred embodiment, the wiper plug 1350 comprises a Multiple Stage Cementer latch-down plug available from Halliburton Energy Services in Dallas, TX modified in a conventional manner for releasable attachment to the expansion mandrel 1305.

In a preferred embodiment, before or after positioning the apparatus 25 1300 within the new section 1230 of the wellbore 1200, a couple of wellbore volumes are circulated in order to ensure that no foreign materials are located within the wellbore 1200 that might clog up the various flow passages and valves of the apparatus 1300 and to ensure that no foreign material interferes with the extrusion process.

30 As illustrated in Fig. 11c, a hardenable fluidic sealing material 1380 is then pumped from a surface location into the fluid passage 1320. The material 1380 then passes from the fluid passage 1320, through the fluid passage 1375,

25791.8

and into the interior region 1370 of the tubular member 1310 below the expandable mandrel 1305. The material 1380 then passes from the interior region 1370 into the fluid passage 1330. The material 1380 then exits the apparatus 1300 via the fluid passage 1335 and fills the annular region 1390
5 between the exterior of the tubular member 1310 and the interior wall of the new section 1230 of the wellbore 1200. Continued pumping of the material 1380 causes the material 1380 to fill up at least a portion of the annular region 1390.

The material 1380 may be pumped into the annular region 1390 at
10 pressures and flow rates ranging, for example, from about 0 to 5000 psi and 0 to 1,500 gallons/min, respectively. In a preferred embodiment, the material 1380 is pumped into the annular region 1390 at pressures and flow rates ranging from about 0 to 5000 psi and 0 to 1,500 gallons/min, respectively, in order to optimally fill the annular region between the tubular member 1310 and the new
15 section 1230 of the wellbore 1200 with the hardenable fluidic sealing material 1380.

The hardenable fluidic sealing material 1380 may comprise any number of conventional commercially available hardenable fluidic sealing materials such as, for example, slag mix, cement or epoxy. In a preferred embodiment, the
20 hardenable fluidic sealing material 1380 comprises blended cements designed specifically for the well section being drilled and available from Halliburton Energy Services in order to optimally provide support for the tubular member 1310 during displacement of the material 1380 in the annular region 1390. The optimum blend of the cement is preferably determined using conventional
25 empirical methods.

The annular region 1390 preferably is filled with the material 1380 in sufficient quantities to ensure that, upon radial expansion of the tubular member 1310, the annular region 1390 of the new section 1230 of the wellbore 1200 will be filled with material 1380.

30 As illustrated in Fig. 11d, once the annular region 1390 has been adequately filled with material 1380, a wiper dart 1395, or other similar device, is introduced into the fluid passage 1320. The wiper dart 1395 is preferably

pumped through the fluid passage 1320 by a non hardenable fluidic material 1381. The wiper dart 1395 then preferably engages the wiper plug 1350.

As illustrated in Fig. 11e, in a preferred embodiment, engagement of the wiper dart 1395 with the wiper plug 1350 causes the wiper plug 1350 to
5 decouple from the mandrel 1305. The wiper dart 1395 and wiper plug 1350 then preferably will lodge in the fluid passage 1330, thereby blocking fluid flow through the fluid passage 1330, and fluidically isolating the interior region 1370 of the tubular member 1310 from the annular region 1390. In a preferred
10 embodiment, the non hardenable fluidic material 1381 is then pumped into the interior region 1370 causing the interior region 1370 to pressurize. Once the interior region 1370 becomes sufficiently pressurized, the tubular member 1310 is extruded off of the expandable mandrel 1305. During the extrusion process, the expandable mandrel 1305 is raised out of the expanded portion of the
tubular member 1310 by the support member 1345.

15 The wiper dart 1395 is preferably placed into the fluid passage 1320 by introducing the wiper dart 1395 into the fluid passage 1320 at a surface location in a conventional manner. The wiper dart 1395 may comprise any number of conventional commercially available devices from plugging a fluid passage such
20 as, for example, Multiple Stage Cementer latch-down plugs, Omega latch-down plugs or three wiper latch-down plug/dart modified in accordance with the teachings of the present disclosure. In a preferred embodiment, the wiper dart 1395 comprises a three wiper latch-down plug modified to latch and seal in the
Multiple Stage Cementer latch down plug 1350. The three wiper latch-down plug is available from Halliburton Energy Services in Dallas, TX.

25 After blocking the fluid passage 1330 using the wiper plug 1330 and wiper dart 1395, the non hardenable fluidic material 1381 may be pumped into the interior region 1370 at pressures and flow rates ranging, for example, from
30 approximately 0 to 5000 psi and 0 to 1,500 gallons/min in order to optimally extrude the tubular member 1310 off of the mandrel 1305. In this manner, the amount of hardenable fluidic material within the interior of the tubular member 1310 is minimized.

In a preferred embodiment, after blocking the fluid passage 1330, the non hardenable fluidic material 1381 is preferably pumped into the interior region 1370 at pressures and flow rates ranging from approximately 500 to 9,000 psi and 40 to 3,000 gallons/min in order to optimally provide operating pressures to maintain the expansion process at rates sufficient to permit adjustments to be made in operating parameters during the extrusion process.

For typical tubular members 1310, the extrusion of the tubular member 1310 off of the expandable mandrel 1305 will begin when the pressure of the interior region 1370 reaches, for example, approximately 500 to 9,000 psi. In a preferred embodiment, the extrusion of the tubular member 1310 off of the expandable mandrel 1305 is a function of the tubular member diameter, wall thickness of the tubular member, geometry of the mandrel, the type of lubricant, the composition of the shoe and tubular member, and the yield strength of the tubular member. The optimum flow rate and operating pressures are preferably determined using conventional empirical methods.

During the extrusion process, the expandable mandrel 1305 may be raised out of the expanded portion of the tubular member 1310 at rates ranging, for example, from about 0 to 5 ft/sec. In a preferred embodiment, during the extrusion process, the expandable mandrel 1305 may be raised out of the expanded portion of the tubular member 1310 at rates ranging from about 0 to 2 ft/sec in order to optimally provide an efficient process, optimally permit operator adjustment of operation parameters, and ensure optimal completion of the extrusion process before curing of the material 1380.

When the upper end portion 1355 of the tubular member 1310 is extruded off of the expandable mandrel 1305, the outer surface of the upper end portion 1355 of the tubular member 1310 will preferably contact the interior surface of the lower end portion of the casing 1215 to form an fluid tight overlapping joint. The contact pressure of the overlapping joint may range, for example, from approximately 50 to 20,000 psi. In a preferred embodiment, the contact pressure of the overlapping joint ranges from approximately 400 to 10,000 psi in order to optimally provide contact pressure sufficient to ensure annular sealing and provide enough resistance to withstand typical tensile and

compressive loads. In a particularly preferred embodiment, the sealing members 1340 will ensure an adequate fluidic and gaseous seal in the overlapping joint.

In a preferred embodiment, the operating pressure and flow rate of the non hardenable fluidic material 1381 is controllably ramped down when the expandable mandrel 1305 reaches the upper end portion 1355 of the tubular member 1310. In this manner, the sudden release of pressure caused by the complete extrusion of the tubular member 1310 off of the expandable mandrel 1305 can be minimized. In a preferred embodiment, the operating pressure is reduced in a substantially linear fashion from 100% to about 10% during the end of the extrusion process beginning when the mandrel 1305 has completed approximately all but about 5 feet of the extrusion process.

Alternatively, or in combination, a shock absorber is provided in the support member 1345 in order to absorb the shock caused by the sudden release of pressure.

Alternatively, or in combination, a mandrel catching structure is provided in the upper end portion 1355 of the tubular member 1310 in order to catch or at least decelerate the mandrel 1305.

Once the extrusion process is completed, the expandable mandrel 1305 is removed from the wellbore 1200. In a preferred embodiment, either before or after the removal of the expandable mandrel 1305, the integrity of the fluidic seal of the overlapping joint between the upper portion 1355 of the tubular member 1310 and the lower portion of the casing 1215 is tested using conventional methods. If the fluidic seal of the overlapping joint between the upper portion 1355 of the tubular member 1310 and the lower portion of the casing 1215 is satisfactory, then the uncured portion of the material 1380 within the expanded tubular member 1310 is then removed in a conventional manner. The material 1380 within the annular region 1390 is then allowed to cure.

As illustrated in Fig. 11f, preferably any remaining cured material 1380 within the interior of the expanded tubular member 1310 is then removed in a conventional manner using a conventional drill string. The resulting new

section of casing 1400 includes the expanded tubular member 1310 and an outer annular layer 1405 of cured material 305. The bottom portion of the apparatus 1300 comprising the shoe 1315 may then be removed by drilling out the shoe 1315 using conventional drilling methods.

5 Referring now to Figs. 12 and 13, a preferred embodiment of a wellhead system 1500, formed using one or more of the embodiments of the apparatus and processes described above with reference to Figs. 1-11f, will be described. The wellhead system 1500 preferably includes a conventional Christmas tree/drilling spool assembly 1505, a thick wall casing 1510, an annular body of
10 cement 1515, an outer casing 1520, an annular body of cement 1525, an intermediate casing 1530, and an inner casing 1535.

The Christmas tree/drilling spool assembly 1505 may comprise any number of conventional Christmas tree/drilling spool assemblies such as, for example, the SS-15 Subsea Wellhead System, Spool Tree Subsea Production
15 System or the Compact Wellhead System available from suppliers such as Drill-Quip, Cameron or Breda, modified in accordance with the teachings of the present disclosure. The drilling spool assembly 1505 is preferably operably
20 coupled to the thick wall casing 1510 and/or the outer casing 1520. The assembly 1505 may be coupled to the thick wall casing 1510 and/or outer casing 1520, for example, by welding, a threaded connection or made from single stock. In a preferred embodiment, the assembly 1505 is coupled to the thick wall casing 1510 and/or outer casing 1520 by welding.

The thick wall casing 1510 is positioned in the upper end of a wellbore 1540. In a preferred embodiment, at least a portion of the thick wall casing
25 1510 extends above the surface 1545 in order to optimally provide easy access and attachment to the Christmas tree/drilling spool assembly 1505. The thick wall casing 1510 is preferably coupled to the Christmas tree/drilling spool assembly 1505, the annular body of cement 1515, and the outer casing 1520.

The thick wall casing 1510 may comprise any number of conventional
30 commercially available high strength wellbore casings such as, for example, Oilfield Country Tubular Goods, titanium tubing or stainless steel tubing. In a preferred embodiment, the thick wall casing 1510 comprises Oilfield Country

Tubular Goods available from various foreign and domestic steel mills. In a preferred embodiment, the thick wall casing 1510 has a yield strength of about 40,000 to 135,000 psi in order to optimally provide maximum burst, collapse, and tensile strengths. In a preferred embodiment, the thick wall casing 1510
5 has a failure strength in excess of about 5,000 to 20,000 psi in order to optimally provide maximum operating capacity and resistance to degradation of capacity after being drilled through for an extended time period.

The annular body of cement 1515 provides support for the thick wall casing 1510. The annular body of cement 1515 may be provided using any
10 number of conventional processes for forming an annular body of cement in a wellbore. The annular body of cement 1515 may comprise any number of conventional cement mixtures.

The outer casing 1520 is coupled to the thick wall casing 1510. The outer casing 1520 may be fabricated from any number of conventional commercially
15 available tubular members modified in accordance with the teachings of the present disclosure. In a preferred embodiment, the outer casing 1520 comprises any one of the expandable tubular members described above with reference to Figs. 1-11f.

In a preferred embodiment, the outer casing 1520 is coupled to the thick
20 wall casing 1510 by expanding the outer casing 1520 into contact with at least a portion of the interior surface of the thick wall casing 1510 using any one of the embodiments of the processes and apparatus described above with reference to Figs. 1-11f. In an alternative embodiment, substantially all of the overlap of the outer casing 1520 with the thick wall casing 1510 contacts with the interior
25 surface of the thick wall casing 1510.

The contact pressure of the interface between the outer casing 1520 and the thick wall casing 1510 may range, for example, from about 500 to 10,000 psi. In a preferred embodiment, the contact pressure between the outer casing 1520 and the thick wall casing 1510 ranges from about 500 to 10,000 psi in
30 order to optimally activate the pressure activated sealing members and to ensure that the overlapping joint will optimally withstand typical extremes of

tensile and compressive loads that are experienced during drilling and production operations.

As illustrated in Fig. 13, in a particularly preferred embodiment, the upper end of the outer casing 1520 includes one or more sealing members 1550 that provide a gaseous and fluidic seal between the expanded outer casing 1520 and the interior wall of the thick wall casing 1510. The sealing members 1550 may comprise any number of conventional commercially available seals such as, for example, lead, plastic, rubber, Teflon or epoxy, modified in accordance with the teachings of the present disclosure. In a preferred embodiment, the sealing members 1550 comprise seals molded from StrataLock epoxy available from Halliburton Energy Services in order to optimally provide an hydraulic seal and a load bearing interference fit between the tubular members. In a preferred embodiment, the contact pressure of the interface between the thick wall casing 1510 and the outer casing 1520 ranges from about 500 to 10,000 psi in order to optimally activate the sealing members 1550 and also optimally ensure that the joint will withstand the typical operating extremes of tensile and compressive loads during drilling and production operations.

In an alternative preferred embodiment, the outer casing 1520 and the thick walled casing 1510 are combined in one unitary member.

The annular body of cement 1525 provides support for the outer casing 1520. In a preferred embodiment, the annular body of cement 1525 is provided using any one of the embodiments of the apparatus and processes described above with reference to Figs. 1-11f.

The intermediate casing 1530 may be coupled to the outer casing 1520 or the thick wall casing 1510. In a preferred embodiment, the intermediate casing 1530 is coupled to the thick wall casing 1510. The intermediate casing 1530 may be fabricated from any number of conventional commercially available tubular members modified in accordance with the teachings of the present disclosure. In a preferred embodiment, the intermediate casing 1530 comprises any one of the expandable tubular members described above with reference to Figs. 1-11f.

In a preferred embodiment, the intermediate casing 1530 is coupled to the thick wall casing 1510 by expanding at least a portion of the intermediate casing 1530 into contact with the interior surface of the thick wall casing 1510 using any one of the processes and apparatus described above with reference to Figs. 1-11f. In an alternative preferred embodiment, the entire length of the overlap of the intermediate casing 1530 with the thick wall casing 1510 contacts the inner surface of the thick wall casing 1510. The contact pressure of the interface between the intermediate casing 1530 and the thick wall casing 1510 may range, for example from about 500 to 10,000 psi. In a preferred embodiment, the contact pressure between the intermediate casing 1530 and the thick wall casing 1510 ranges from about 500 to 10,000 psi in order to optimally activate the pressure activated sealing members and to optimally ensure that the joint will withstand typical operating extremes of tensile and compressive loads experienced during drilling and production operations.

As illustrated in Fig. 13, in a particularly preferred embodiment, the upper end of the intermediate casing 1530 includes one or more sealing members 1560 that provide a gaseous and fluidic seal between the expanded end of the intermediate casing 1530 and the interior wall of the thick wall casing 1510. The sealing members 1560 may comprise any number of conventional commercially available seals such as, for example, plastic, lead, rubber, Teflon or epoxy, modified in accordance with the teachings of the present disclosure. In a preferred embodiment, the sealing members 1560 comprise seals molded from StrataLock epoxy available from Halliburton Energy Services in order to optimally provide a hydraulic seal and a load bearing interference fit between the tubular members.

In a preferred embodiment, the contact pressure of the interface between the expanded end of the intermediate casing 1530 and the thick wall casing 1510 ranges from about 500 to 10,000 psi in order to optimally activate the sealing members 1560 and also optimally ensure that the joint will withstand typical operating extremes of tensile and compressive loads that are experienced during drilling and production operations.

The inner casing 1535 may be coupled to the outer casing 1520 or the thick wall casing 1510. In a preferred embodiment, the inner casing 1535 is coupled to the thick wall casing 1510. The inner casing 1535 may be fabricated from any number of conventional commercially available tubular members
5 modified in accordance with the teachings of the present disclosure. In a preferred embodiment, the inner casing 1535 comprises any one of the expandable tubular members described above with reference to Figs. 1-11f.

In a preferred embodiment, the inner casing 1535 is coupled to the outer casing 1520 by expanding at least a portion of the inner casing 1535 into
10 contact with the interior surface of the thick wall casing 1510 using any one of the processes and apparatus described above with reference to Figs. 1-11f. In an alternative preferred embodiment, the entire length of the overlap of the inner casing 1535 with the thick wall casing 1510 and intermediate casing 1530 contacts the inner surfaces of the thick wall casing 1510 and intermediate
15 casing 1530. The contact pressure of the interface between the inner casing 1535 and the thick wall casing 1510 may range, for example from about 500 to 10,000 psi. In a preferred embodiment, the contact pressure between the inner casing 1535 and the thick wall casing 1510 ranges from about 500 to 10,000 psi in order to optimally activate the pressure activated sealing members and to
20 ensure that the joint will withstand typical extremes of tensile and compressive loads that are commonly experienced during drilling and production operations.

As illustrated in Fig. 13, in a particularly preferred embodiment, the upper end of the inner casing 1535 includes one or more sealing members 1570 that provide a gaseous and fluidic seal between the expanded end of the inner
25 casing 1535 and the interior wall of the thick wall casing 1510. The sealing members 1570 may comprise any number of conventional commercially available seals such as, for example, lead, plastic, rubber, Teflon or epoxy, modified in accordance with the teachings of the present disclosure. In a preferred embodiment, the sealing members 1570 comprise seals molded from
30 StrataLock epoxy available from Halliburton Energy Services in order to optimally provide an hydraulic seal and a load bearing interference fit. In a

preferred embodiment, the contact pressure of the interface between the expanded end of the inner casing 1535 and the thick wall casing 1510 ranges from about 500 to 10,000 psi in order to optimally activate the sealing members 1570 and also to optimally ensure that the joint will withstand typical operating
5 extremes of tensile and compressive loads that are experienced during drilling and production operations.

In an alternative embodiment, the inner casings, 1520, 1530 and 1535, may be coupled to a previously positioned tubular member that is in turn coupled to the outer casing 1510. More generally, the present preferred
10 embodiments may be used to form a concentric arrangement of tubular members.

A method of creating a casing in a borehole located in a subterranean formation has been described that includes installing a tubular liner and a mandrel in the borehole. A body of fluidic material is then injected into the
15 borehole. The tubular liner is then radially expanded by extruding the liner off of the mandrel. The injecting preferably includes injecting a hardenable fluidic sealing material into an annular region located between the borehole and the exterior of the tubular liner; and a non hardenable fluidic material into an interior region of the tubular liner below the mandrel. The method preferably
20 includes fluidically isolating the annular region from the interior region before injecting the second quantity of the non hardenable sealing material into the interior region. The injecting the hardenable fluidic sealing material is preferably provided at operating pressures and flow rates ranging from about 0 to 5000 psi and 0 to 1,500 gallons/min. The injecting of the non hardenable
25 fluidic material is preferably provided at operating pressures and flow rates ranging from about 500 to 9000 psi and 40 to 3,000 gallons/min. The injecting of the non hardenable fluidic material is preferably provided at reduced operating pressures and flow rates during an end portion of the extruding. The non hardenable fluidic material is preferably injected below the mandrel. The
30 method preferably includes pressurizing a region of the tubular liner below the mandrel. The region of the tubular liner below the mandrel is preferably pressurized to pressures ranging from about 500 to 9,000 psi. The method

preferably includes fluidically isolating an interior region of the tubular liner from an exterior region of the tubular liner. The method further preferably includes curing the hardenable sealing material, and removing at least a portion of the cured sealing material located within the tubular liner. The method
5 further preferably includes overlapping the tubular liner with an existing wellbore casing. The method further preferably includes sealing the overlap between the tubular liner and the existing wellbore casing. The method further preferably includes supporting the extruded tubular liner using the overlap with the existing wellbore casing. The method further preferably includes
10 testing the integrity of the seal in the overlap between the tubular liner and the existing wellbore casing. The method further preferably includes removing at least a portion of the hardenable fluidic sealing material within the tubular liner before curing. The method further preferably includes lubricating the surface of the mandrel. The method further preferably includes absorbing
15 shock. The method further preferably includes catching the mandrel upon the completion of the extruding.

An apparatus for creating a casing in a borehole located in a subterranean formation has been described that includes a support member, a mandrel, a tubular member, and a shoe. The support member includes a first
20 fluid passage. The mandrel is coupled to the support member and includes a second fluid passage. The tubular member is coupled to the mandrel. The shoe is coupled to the tubular liner and includes a third fluid passage. The first, second and third fluid passages are operably coupled. The support member preferably further includes a pressure relief passage, and a flow control valve
25 coupled to the first fluid passage and the pressure relief passage. The support member further preferably includes a shock absorber. The support member preferably includes one or more sealing members adapted to prevent foreign material from entering an interior region of the tubular member. The mandrel is preferably expandable. The tubular member is preferably fabricated from
30 materials selected from the group consisting of Oilfield Country Tubular Goods, 13 chromium steel tubing/casing, and plastic casing. The tubular member preferably has inner and outer diameters ranging from about 3 to 15.5 inches

and 3.5 to 16 inches, respectively. The tubular member preferably has a plastic yield point ranging from about 40,000 to 135,000 psi. The tubular member preferably includes one or more sealing members at an end portion. The tubular member preferably includes one or more pressure relief holes at an end
5 portion. The tubular member preferably includes a catching member at an end portion for slowing down the mandrel. The shoe preferably includes an inlet port coupled to the third fluid passage, the inlet port adapted to receive a plug for blocking the inlet port. The shoe preferably is drillable.

A method of joining a second tubular member to a first tubular member,
10 the first tubular member having an inner diameter greater than an outer diameter of the second tubular member, has been described that includes positioning a mandrel within an interior region of the second tubular member, positioning the first and second tubular members in an overlapping relationship, pressurizing a portion of the interior region of the second tubular
15 member; and extruding the second tubular member off of the mandrel into engagement with the first tubular member. The pressurizing of the portion of the interior region of the second tubular member is preferably provided at operating pressures ranging from about 500 to 9,000 psi. The pressurizing of the portion of the interior region of the second tubular member is preferably
20 provided at reduced operating pressures during a latter portion of the extruding. The method further preferably includes sealing the overlap between the first and second tubular members. The method further preferably includes supporting the extruded first tubular member using the overlap with the second tubular member. The method further preferably includes lubricating the
25 surface of the mandrel. The method further preferably includes absorbing shock.

A liner for use in creating a new section of wellbore casing in a subterranean formation adjacent to an already existing section of wellbore casing has been described that includes an annular member. The annular
30 member includes one or more sealing members at an end portion of the annular member, and one or more pressure relief passages at an end portion of the annular member.

A wellbore casing has been described that includes a tubular liner and an annular body of a cured fluidic sealing material. The tubular liner is formed by the process of extruding the tubular liner off of a mandrel. The tubular liner is preferably formed by the process of placing the tubular liner and mandrel
5 within the wellbore, and pressurizing an interior portion of the tubular liner. The annular body of the cured fluidic sealing material is preferably formed by the process of injecting a body of hardenable fluidic sealing material into an annular region external of the tubular liner. During the pressurizing, the interior portion of the tubular liner is preferably fluidically isolated from an
10 exterior portion of the tubular liner. The interior portion of the tubular liner is preferably pressurized to pressures ranging from about 500 to 9,000 psi. The tubular liner preferably overlaps with an existing wellbore casing. The wellbore casing preferably further includes a seal positioned in the overlap between the tubular liner and the existing wellbore casing. Tubular liner is preferably
15 supported the overlap with the existing wellbore casing.

A method of repairing an existing section of a wellbore casing within a borehole has been described that includes installing a tubular liner and a mandrel within the wellbore casing, injecting a body of a fluidic material into the borehole, pressurizing a portion of an interior region of the tubular liner,
20 and radially expanding the liner in the borehole by extruding the liner off of the mandrel. In a preferred embodiment, the fluidic material is selected from the group consisting of slag mix, cement, drilling mud, and epoxy. In a preferred embodiment, the method further includes fluidically isolating an interior region of the tubular liner from an exterior region of the tubular liner. In a preferred
25 embodiment, the injecting of the body of fluidic material is provided at operating pressures and flow rates ranging from about 500 to 9,000 psi and 40 to 3,000 gallons/min. In a preferred embodiment, the injecting of the body of fluidic material is provided at reduced operating pressures and flow rates during an end portion of the extruding. In a preferred embodiment, the fluidic
30 material is injected below the mandrel. In a preferred embodiment, a region of the tubular liner below the mandrel is pressurized. In a preferred embodiment, the region of the tubular liner below the mandrel is pressurized to pressures

ranging from about 500 to 9,000 psi. In a preferred embodiment, the method further includes overlapping the tubular liner with the existing wellbore casing. In a preferred embodiment, the method further includes sealing the interface between the tubular liner and the existing wellbore casing. In a preferred
5 embodiment, the method further includes supporting the extruded tubular liner using the existing wellbore casing. In a preferred embodiment, the method further includes testing the integrity of the seal in the interface between the tubular liner and the existing wellbore casing. In a preferred embodiment, method further includes lubricating the surface of the mandrel. In a preferred
10 embodiment, the method further includes absorbing shock. In a preferred embodiment, the method further includes catching the mandrel upon the completion of the extruding. In a preferred embodiment, the method further includes expanding the mandrel in a radial direction.

A tie-back liner for lining an existing wellbore casing has been described
15 that includes a tubular liner and an annular body of a cured fluidic sealing material. The tubular liner is formed by the process of extruding the tubular liner off of a mandrel. The annular body of a cured fluidic sealing material is coupled to the tubular liner. In a preferred embodiment, the tubular liner is formed by the process of placing the tubular liner and mandrel within the
20 wellbore, and pressurizing an interior portion of the tubular liner. In a preferred embodiment, during the pressurizing, the interior portion of the tubular liner is fluidically isolated from an exterior portion of the tubular liner. In a preferred embodiment, the interior portion of the tubular liner is pressurized at pressures ranging from about 500 to 9,000 psi. In a preferred
25 embodiment, the annular body of a cured fluidic sealing material is formed by the process of injecting a body of hardenable fluidic sealing material into an annular region between the existing wellbore casing and the tubular liner. In a preferred embodiment, the tubular liner overlaps with another existing wellbore casing. In a preferred embodiment, the tie-back liner further includes
30 a seal positioned in the overlap between the tubular liner and the other existing wellbore casing. In a preferred embodiment, tubular liner is supported by the overlap with the other existing wellbore casing.

An apparatus for expanding a tubular member has been described that includes a support member, a mandrel, a tubular member, and a shoe. The support member includes a first fluid passage. The mandrel is coupled to the support member. The mandrel includes a second fluid passage operably coupled
5 to the first fluid passage, an interior portion, and an exterior portion. The interior portion of the mandrel is drillable. The tubular member is coupled to the mandrel. The shoe is coupled to the tubular member. The shoe includes a third fluid passage operably coupled to the second fluid passage, an interior portion, and an exterior portion. The interior portion of the shoe is drillable.
10 Preferably, the interior portion of the mandrel includes a tubular member and a load bearing member. Preferably, the load bearing member comprises a drillable body. Preferably, the interior portion of the shoe includes a tubular member, and a load bearing member. Preferably, the load bearing member comprises a drillable body. Preferably, the exterior portion of the mandrel
15 comprises an expansion cone. Preferably, the expansion cone is fabricated from materials selected from the group consisting of tool steel, titanium, and ceramic. Preferably, the expansion cone has a surface hardness ranging from about 58 to 62 Rockwell C. Preferably at least a portion of the apparatus is drillable.

20 An wellhead has also been described that includes an outer casing and a plurality of substantially concentric and overlapping inner casings coupled to the outer casing. Each inner casing is supported by contact pressure between an outer surface of the inner casing and an inner surface of the outer casing. In a preferred embodiment, the outer casing has a yield strength ranging from
25 about 40,000 to 135,000 psi. In a preferred embodiment, the outer casing has a burst strength ranging from about 5,000 to 20,000 psi. In a preferred embodiment, the contact pressure between the inner casings and the outer casing ranges from about 500 to 10,000 psi. In a preferred embodiment, one or more of the inner casings include one or more sealing members that contact
30 with an inner surface of the outer casing. In a preferred embodiment, the sealing members are selected from the group consisting of lead, rubber, Teflon, epoxy, and plastic. In a preferred embodiment, a Christmas tree is coupled to

the outer casing. In a preferred embodiment, a drilling spool is coupled to the outer casing. In a preferred embodiment, at least one of the inner casings is a production casing.

A wellhead has also been described that includes an outer casing at least
5 partially positioned within a wellbore and a plurality of substantially concentric inner casings coupled to the interior surface of the outer casing by the process of expanding one or more of the inner casings into contact with at least a portion of the interior surface of the outer casing. In a preferred embodiment, the inner casings are expanded by extruding the inner casings off of a mandrel.
10 In a preferred embodiment, the inner casings are expanded by the process of placing the inner casing and a mandrel within the wellbore; and pressurizing an interior portion of the inner casing. In a preferred embodiment, during the pressurizing, the interior portion of the inner casing is fluidically isolated from an exterior portion of the inner casing. In a preferred embodiment, the interior
15 portion of the inner casing is pressurized at pressures ranging from about 500 - to 9,000 psi. In a preferred embodiment, one or more seals are positioned in the interface between the inner casings and the outer casing. In a preferred embodiment, the inner casings are supported by their contact with the outer casing.

20 A method of forming a wellhead has also been described that includes drilling a wellbore. An outer casing is positioned at least partially within an upper portion of the wellbore. A first tubular member is positioned within the outer casing. At least a portion of the first tubular member is expanded into contact with an interior surface of the outer casing. A second tubular member
25 is positioned within the outer casing and the first tubular member. At least a portion of the second tubular member is expanded into contact with an interior portion of the outer casing. In a preferred embodiment, at least a portion of the interior of the first tubular member is pressurized. In a preferred embodiment, at least a portion of the interior of the second tubular member is
30 pressurized. In a preferred embodiment, at least a portion of the interiors of the first and second tubular members are pressurized. In a preferred embodiment, the pressurizing of the portion of the interior region of the first

tubular member is provided at operating pressures ranging from about 500 to 9,000 psi. In a preferred embodiment, the pressurizing of the portion of the interior region of the second tubular member is provided at operating pressures ranging from about 500 to 9,000 psi. In a preferred embodiment, the

5 pressurizing of the portion of the interior region of the first and second tubular members is provided at operating pressures ranging from about 500 to 9,000 psi. In a preferred embodiment, the pressurizing of the portion of the interior region of the first tubular member is provided at reduced operating pressures during a latter portion of the expansion. In a preferred embodiment, the

10 pressurizing of the portion of the interior region of the second tubular member is provided at reduced operating pressures during a latter portion of the expansion. In a preferred embodiment, the pressurizing of the portion of the interior region of the first and second tubular members is provided at reduced operating pressures during a latter portion of the expansions. In a preferred

15 embodiment, the contact between the first tubular member and the outer casing is sealed. In a preferred embodiment, the contact between the second tubular member and the outer casing is sealed. In a preferred embodiment, the contact between the first and second tubular members and the outer casing is sealed. In a preferred embodiment, the expanded first tubular member is

20 supported using the contact with the outer casing. In a preferred embodiment, the expanded second tubular member is supported using the contact with the outer casing. In a preferred embodiment, the expanded first and second tubular members are supported using their contacts with the outer casing. In a preferred embodiment, the first and second tubular members are extruded off

25 of a mandrel. In a preferred embodiment, the surface of the mandrel is lubricated. In a preferred embodiment, shock is absorbed. In a preferred embodiment, the mandrel is expanded in a radial direction. In a preferred embodiment, the first and second tubular members are positioned in an overlapping relationship. In a preferred embodiment, an interior region of the

30 first tubular member is fluidically isolated from an exterior region of the first tubular member. In a preferred embodiment, an interior region of the second tubular member is fluidically isolated from an exterior region of the second

tubular member. In a preferred embodiment, the interior region of the first tubular member is fluidically isolated from the region exterior to the first tubular member by injecting one or more plugs into the interior of the first tubular member. In a preferred embodiment, the interior region of the second tubular member is fluidically isolated from the region exterior to the second tubular member by injecting one or more plugs into the interior of the second tubular member. In a preferred embodiment, the pressurizing of the portion of the interior region of the first tubular member is provided by injecting a fluidic material at operating pressures and flow rates ranging from about 500 to 9,000 psi and 40 to 3,000 gallons/minute. In a preferred embodiment, the pressurizing of the portion of the interior region of the second tubular member is provided by injecting a fluidic material at operating pressures and flow rates ranging from about 500 to 9,000 psi and 40 to 3,000 gallons/minute. In a preferred embodiment, fluidic material is injected beyond the mandrel. In a preferred embodiment, a region of the tubular members beyond the mandrel is pressurized. In a preferred embodiment, the region of the tubular members beyond the mandrel is pressurized to pressures ranging from about 500 to 9,000 psi. In a preferred embodiment, the first tubular member comprises a production casing. In a preferred embodiment, the contact between the first tubular member and the outer casing is sealed. In a preferred embodiment, the contact between the second tubular member and the outer casing is sealed. In a preferred embodiment, the expanded first tubular member is supported using the outer casing. In a preferred embodiment, the expanded second tubular member is supported using the outer casing. In a preferred embodiment, the integrity of the seal in the contact between the first tubular member and the outer casing is tested. In a preferred embodiment, the integrity of the seal in the contact between the second tubular member and the outer casing is tested. In a preferred embodiment, the mandrel is caught upon the completion of the extruding. In a preferred embodiment, the mandrel is drilled out. In a preferred embodiment, the mandrel is supported with coiled tubing. In a preferred embodiment, the mandrel is coupled to a drillable shoe.

An apparatus has also been described that includes an outer tubular member, and a plurality of substantially concentric and overlapping inner tubular members coupled to the outer tubular member. Each inner tubular member is supported by contact pressure between an outer surface of the inner casing and an inner surface of the outer inner tubular member. In a preferred embodiment, the outer tubular member has a yield strength ranging from about 40,000 to 135,000 psi. In a preferred embodiment, the outer tubular member has a burst strength ranging from about 5,000 to 20,000 psi. In a preferred embodiment, the contact pressure between the inner tubular members and the outer tubular member ranges from about 500 to 10,000 psi. In a preferred embodiment, one or more of the inner tubular members include one or more sealing members that contact with an inner surface of the outer tubular member. In a preferred embodiment, the sealing members are selected from the group consisting of rubber, lead, plastic, and epoxy.

An apparatus has also been described that includes an outer tubular member, and a plurality of substantially concentric inner tubular members coupled to the interior surface of the outer tubular member by the process of expanding one or more of the inner tubular members into contact with at least a portion of the interior surface of the outer tubular member. In a preferred embodiment, the inner tubular members are expanded by extruding the inner tubular members off of a mandrel. In a preferred embodiment, the inner tubular members are expanded by the process of: placing the inner tubular members and a mandrel within the outer tubular member; and pressurizing an interior portion of the inner casing. In a preferred embodiment, during the pressurizing, the interior portion of the inner tubular member is fluidically isolated from an exterior portion of the inner tubular member. In a preferred embodiment, the interior portion of the inner tubular member is pressurized at pressures ranging from about 500 to 9,000 psi. In a preferred embodiment, the apparatus further includes one or more seals positioned in the interface between the inner tubular members and the outer tubular member. In a preferred embodiment, the inner tubular members are supported by their contact with the outer tubular member.

Although illustrative embodiments of the invention have been shown and described, a wide range of modification, changes and substitution is contemplated in the foregoing disclosure. In some instances, some features of the present invention may be employed without a corresponding use of the other features. Accordingly, it is appropriate that the appended claims be construed broadly and in a manner consistent with the scope of the invention.

Claims

- 1 1. A wellhead, comprising:
 - 2 an outer casing; and
 - 3 a plurality of substantially concentric and overlapping inner casings
 - 4 coupled to the outer casing;
 - 5 wherein each inner casing is supported by contact pressure between an
 - 6 outer surface of the inner casing and an inner surface of the outer
 - 7 casing.

- 1 2. A wellhead, comprising:
 - 2 an outer casing at least partially positioned within a wellbore; and
 - 3 a plurality of substantially concentric inner casings coupled to the
 - 4 interior surface of the outer casing by the process of expanding
 - 5 one or more of the inner casings into contact with at least a
 - 6 portion of the interior surface of the outer casing.

- 1 3. A method of forming a wellhead, comprising:
 - 2 drilling a wellbore;
 - 3 positioning an outer casing at least partially within an upper portion of
 - 4 the wellbore;
 - 5 positioning a first tubular member within the outer casing;
 - 6 expanding at least a portion of the first tubular member into contact
 - 7 with an interior surface of the outer casing;
 - 8 positioning a second tubular member within the outer casing and the
 - 9 first tubular member; and
 - 10 expanding at least a portion of the second tubular member into contact
 - 11 with an interior portion of the outer casing.

- 1 4. An apparatus, comprising:
 - 2 an outer tubular member; and
 - 3 a plurality of substantially concentric and overlapping inner tubular
 - 4 members coupled to the outer tubular member;

5 wherein each inner tubular member is supported by contact pressure
6 between an outer surface of the inner casing and an inner surface
7 of the outer inner tubular member.

1 5. An apparatus, comprising:
2 an outer tubular member; and
3 a plurality of substantially concentric inner tubular members coupled to
4 the interior surface of the outer tubular member by the process of
5 expanding one or more of the inner tubular members into contact
6 with at least a portion of the interior surface of the outer tubular
7 member.



INVESTOR IN PEOPLE

Application N : GB 0003251.6
Claims searched: 1-5

Examiner: Peter Mason
Date of search: 13 July 2000

**Patents Act 1977
Search Report under Section 17**

Databases searched:

UK Patent Office collections, including GB, EP, WO & US patent specifications, in:
UK CI (Ed.R): E1F: FLA, FJR
Int CI (Ed.7): E21B:
Other: Online: JAPIO, EPODOC, WPI

Documents considered to be relevant:

| Category | Identity of document and relevant passage | Relevant to claims |
|----------|---|--------------------|
| | NONE FOUND | |

| | | | |
|---|---|---|--|
| X | Document indicating lack of novelty or inventive step | A | Document indicating technological background and/or state of the art. |
| Y | Document indicating lack of inventive step if combined with one or more other documents of same category. | P | Document published on or after the declared priority date but before the filing date of this invention. |
| & | Member of the same patent family | E | Patent document published on or after, but with priority date earlier than, the filing date of this application. |